

PLANETA – PREMIUM PRO

Compact and light

The new PREMIUM-PRO chain hoist is the systematic development of the established PREMIUM series and is manufactured using the latest technology. Compared to its predecessors, it is much lighter and provides better handling thanks to its compact design.

Despite the weight saving, working stability has been improved thanks to the clever construction. The chrome-plated housing for corrosion protection and overload protection as standard reinforce the high quality of the PLANETA-PREMIUM PRO product.

Load chain

Tempered and galvanised load chain „Made in Germany“ according to DIN EN 818-7-T. **Up to 3 t in a single strand.**

Higher lifting on request, any length can be delivered.

Galvanised or chromated on all sides

Dirt or rain have no effect on this device.

All connection and housing parts are protected against corrosion.

Chain mounting

Thanks to the easily-accessible chain mounting, any user can insert a longer chain if required.



PREMIUM PRO
1 t

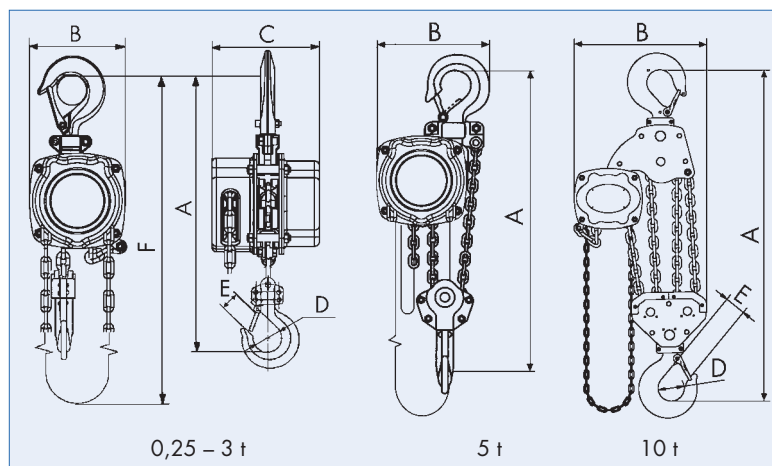

0,25 – 3 t

5 t

10 t



PREMIUM PRO
5 t



PREMIUM PRO
10 t

TYPE	PREMIUM PRO...	0,25	0,5	1	1,5	2	3	5	10	20	30
Capacity	t	0.25	0.5	1	1.5	2	3	5	10	20	30
Standard lift	m	3	3	3	3	3	3	3	3	3	3
Min. headroom (A)	mm	259	309	373	460	460	553	630	900	1033	1320
Hand chain force	daN	22	24	30.5	36	36	37	39	39.5	40.5	47 x 2
Hand chain operation length	m	2.5	2.5	2.5	2.5	2.5	2.5	2.5	2.5	2.5	2.5
Number of chain falls		1	1	1	1	1	1	2	4	8	12
Chain size	mm	4 x 12	5 x 15	6 x 18	8 x 24	8 x 24	10 x 30	10 x 30	10 x 30	10 x 30	9 x 27
B (Dimensions)	mm	95	114	152	190	190	240	240	391	955	690
C	mm	99.4	110	139	150	150	158	158	166	169	435
D	mm	30	33	40	52	52	62	72	85	110	106
E	mm	22	22	28	33	33	37	44	60	70	80
F	m	2.5	2.5	2.5	2.5	2.5	2.5	2.5	2.5	2.5	2.5
Weight with 3 m lift	kg	4.2	5.7	10.8	16.8	17.1	26.2	40	62	160	350
Weight for 1 m additional lift	kg	0.35	0.55	0.78	1.4	1.4	2.2	4.4	8.8	17.6	21.6
PREMIUM PRO ... with 3 m lift	Order No.	G10310	G10311	G10312	G10313	G10314	G10315	G10316	G10317	G10318	G10062
Additional 1 m lift	Order No.	G10270	G10271	G10242	G10243	G10243	G10272	G10246	G20247	G10248	G10058
Chain bag (plastic) up to 3 m lift	Order No.	H10057	H10057	H10057	H10059	H10059	-	-	-	-	-

Safety brake

The reliable disc brake holds the load in any position after the lifting or lowering process is complete. Of course, the brake discs are free of asbestos.

Housing

Even in harsh conditions, dust and dirt have no chance. The brake and pawls are well protected.

Hooks

Forged carrying and load hooks made of heat-treated, tempered steel. Cast hook clips that are galvanized and spring-loaded prevent lifting gear slipping.

Options:

- Short model as a combination of chain hoist PREMIUM PRO and trolley
- Chain bag as an accessory
- Also available with GL (Germanischer Lloyd) certification! For shipyards, ships and the chemical industry.
-  -Design

