

PLANETA - PLM-II

The manual chain hoist **PLANETA-PLM-II** is our valued price alternative to many hoists on the market. It complies fully with all relevant International standards and the CE-regulations for Europe. Its solid design and easy way of handling made him many friends through the last years. You will find PLM-II in many kinds of industry, shipyards, on cranes and also for maintenance.

Safety brake

The large sized safety brake works instantly when operation is stopped, holding the load safely in any position.

Reliable material

The housings are made of steel, the hook holder and sheeves are of cast steel. This makes PLM-II robust and sturdy.

Swivel hook

Top and bottom hook are out of tempered high tensile steel. They have spring loaded, galvanized safety latches with side bending protection.

Luxury rust protection

Screws, nuts, discs, washers, bolts, the complete middle section and the chains are galvanized to offer a reliable corrosion protection.

All other steel parts are painted or powder-coated with our best blue finish. Top quality load chain accords to DIN EN 818-7-T and shines zinc galvanized.

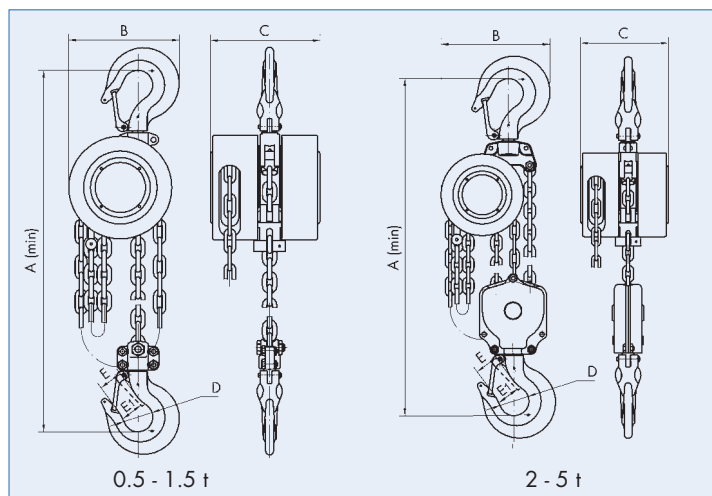

Completely zinc plated internal housing

PLM-II 5 t

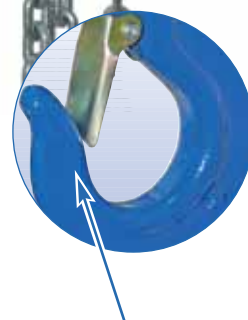

Die-forged safety hook with locking safety latch

TYPE	PLM-II...	0,5	1	1,5	2	3	5
Capacity	t	0.5	1	1.5	2	3	5
Standard lift	m	3	3	3	3	3	3
Min. Headroom (A)	mm	295	310	390	410	480	600
Hand chain force	daN	22	30	34	31	34	38
Hand chain operation length	m	2.5	2.5	2.5	2.5	2.5	2.5
Number of Chain falls		1	1	1	2	2	2
Chain size	mm	5 x 15	6 x 18	8 x 24	6 x 18	8 x 24	10 x 30
B (Dimensions)	mm	122	146	178	142	178	210
C	mm	108	122	139	122	139	162
D	mm	32	38	42	45	50	65
E	mm	18.5	24.5	29.5	31	33	45.5
E1	mm	15	19.5	22	26.5	30	40.5
Weight with 3 m lift	kg	8	11	15	14	25	36
Weight for 1 m additional lift	kg	1.2	1.7	2.3	2.5	3.7	5.3
PLM-II... with 3 m lift	Order No.	G10235	G10236	G10237	G10238	G10239	G10240
Additional 1 m lift	Order No.	G10241	G10242	G10243	G10244	G10245	G10246
Chain bag (plastic) up to 3 m lift	Order No.	H10057	H10057	H10059	H10058	-	-