



Hartmann & König
STROMZUFÜHRUNGS AG

Spring cable reels



*Your partner for energy and data transmission systems
for mobile consumers*

CONCEIVE
CONNECT
CONDUCT





List of Contents

| | |
|--|----|
| General | 01 |
| Type Key | 03 |
| Arrangement Examples | 04 |
| Spring Cable Reeling Drums LT, LTAI-II horizontal | 05 |
| Spring Cable Reeling Drums LT, LTAI-II horizontal (freely suspended) | 10 |
| Spring Cable Reeling Drums LT, LTAI-II horizontal (vertically downwards) | 14 |
| Dimension Sheets LT, LTAI-II | 19 |
| Spring Cable Reeling Drums LTSP, LTAISP, LTAIISP | 23 |
| Dimension Sheets LTSP, LTAISP, LTAIISP | 25 |
| Spring Cable Reeling Drums LTB, LTB...SP | 26 |
| Spring Cable Reeling Drums LTSCH, LTAISCH, LTAIISCH | 27 |
| Dimension Sheets LTSCH, LTAISCH, LTAIISCH | 29 |
| Spring Cable Reeling Drums slipringless LTS | 30 |
| Dimension Sheets LTS | 31 |
| Cable Reeling Drums for Counterweight Drive KTGI, KTGII, KTGIII | 32 |
| Dimension Sheets KTGI, KTGII, KTGIII | 35 |
| Accessories | 37 |
| Questionnaire | 47 |
| Technical Explanations | 48 |
| General Terms of Supply | 51 |



General

Application

Cable reeling drums with spring drive are used for current supply to mobile consumers that need automatic winding of flexible energy or control lines.

Application Areas

Portal and slewing cranes of all types, deck cranes, according to ship classifications, DET NORSKE VERITAS, Lloyd's Register of Shipping or German Lloyd. Mobile cranes, construction cranes, loading plants, magnet and grab cranes, E-trains, travelling platforms, lifting platforms, stapler, longitudinal scrapers in sewage treatment plants, charging plants, palletising plants, aisle stackers etc.

Our cable reeling drums conform to VDE or EN and accident prevention regulations (UVV) regulations.

Special Cases of Use

- Drums for installation onboard sea ships or for applications in the tropics.
- Drums for aggressive operating conditions acid baths, in galvanising trades, sewage treatment plants.
- Drums for measuring current, signal current or high-frequency transmission.
- Drums for the supply of liquid or gaseous media (hose reeling drums).
- Drums for the application with flexible wire rope (rope drums) e.g. for road indicators in connection with copying works and potentiometer or for easing grippers.
- Drums for untaught cable payout (curves or circular tracks with rotary ranges of up to 360° and above).
- Drums with interlock device (ratchet) for height adjustable tools or control switch on lifting gear.
- Drums for coiling flat cables (especially for lifting platforms, palletising apparatus, machine tools).
- Drums for spiral coiling.

For these and application cases not listed above, we are at your disposal with advice and deed and look forward to your enquiry.

Protection Class

The housing of slip ring body is encapsulated according to protection system IP55 (higher protection systems available on request).

Drive

The springcable reeling drum is driven by means spiral leaf spring. The durability of drum-drive springs is dependent on the type of operation. The expected number of spring oscillations is approx. **120.000**. For this purpose, we use only special spring steels in order to attain longer service life of the spiral leaf spring.

Drum's Direction of Rotation

In standard configuration, cable payout occurs on the **left** of the slip ring body or rotary valve, and it is depicted in the dimension drawings. Opposite alignment can also be supplied.

Limitation of Stop Position

Drum can be supplied with a cam limit switch for extra payment. This serves **only** for limiting the stop position.

Measures for Accident Prevention

For the drums with chain drive, it is provided with cladding so that the drums can be used in accordance with the accident prevention regulations and the law about technical working means in traffic or working area. Further protection measures, like the possibly required cladding of a revolving storage drum body, must be provided on both sides and adjusted to the respective mounting conditions.

Surface Protection

The sheet metal parts of the cable reeling drums LT155 – LTAII700 are in galvanised version. All other parts are provided with priming and cover coat in 2 component epoxy resin according to RAL 7031 blue-grey. Other colours are available on request.

Maintenance Instructions

The operating instructions required for assembly and commissioning are attached to every drum with a delivery note.

Suitability of Cable reeling Drums

maximum driving and lifting velocity
 $v = 60 \text{ m/min}$
maximum driving acceleration
 $a = 0.2 \text{ m/s}^2$



General

Overall Length of Cable

The length of cable is calculated from the operationally required coiling length + mounting height of drum + 2 safety windings + connection length.

Guarantee

We provide guarantee according to General Terms of Supply by Hartmann & König Stromzuführungs AG (from page 51). The drum drive springs, wear parts are excluded from guarantee.

Note

Hartmann & König is developed, constructed and produced according to the

- Low Voltage Directive 2006/95/EG
- EMC Directive 2004/108/EG
- Generally valid manufacturing guidelines according to ISO 9001:2000

Drum reeling Cables

Cables suitable for reeling on drums, which conform to the mechanical requirements, must be used. For the selection of cables, we refer to our catalogue page 48.

Determining the required cable cross-section by calculation, by considering the permissible voltage drop for three-phase current

$$A = \frac{\sqrt{3} \times L \times IG \times \cos \varphi}{\Delta U \times \chi} \text{ (mm}^2\text{)}$$

Explanation of Formula Symbols

| | | |
|-------|---|---|
| A | = | required cable cross-section (mm ²) |
| L | = | overall length of drum-reeled cable (m) |
| IG | = | total current consumption (A) |
| cos φ | = | power factor = approx. 0.8 |
| χ | = | conductivity (for copper = 56) |
| Δ U | = | permissible voltage drop (V) |

Determining the required cable cross-section with consideration of permissible thermal load capacity

For the cables based on the drum selection table, the loading values "current capacity" page 48 are valid for cable laid freely in air with 4 loaded conductors. The values apply to an ambient temperature of 30°C. For other ambient temperatures, other conversion factors are valid.

The current loading values mentioned on page 48 are only limitedly applicable to cables in drum operation. The following table "conversion factors" specifies conversion factors for power rating in dependence on the type of drum reeling. They are valid for continuous full-reeled cables.

In practice, however, operating state applies to different devices that do not fully require full consideration of these conversion factors, since the cable is only temporarily fully coiled. In these cases, corresponding mean values should be used for calculation.

As for spirally coiled cables, permissible loading values for single layer coils are applicable.

The loading values according to "current capacity" apply also to 4-wire cables. Likewise, they are also permissible for five-wire arrangements if one of the conductors is used as protective earth.

As for multiple wire cables, we recommend the following conversion factors based on the number of loaded wires (Table conversion factors).

The loading values listed "current capacity" on page 48 apply to continuous load.



General

Type Key

| | | | | | | | | | | | |
|---|-------|---|-----|---|---|---|------|---|---|---|-----|
| | LT | - | 220 | - | 2 | - | 551H | - | 4 | - | 26 |
| | LTAI | - | 530 | - | 4 | - | 524 | - | 5 | - | 150 |
| | LTAII | - | 700 | - | 6 | - | 525 | - | 4 | - | 220 |
| design | | | | | | | | | | | |
| drum size | | | | | | | | | | | |
| numbers of springs | | | | | | | | | | | |
| spring type serial (H) or parallel | | | | | | | | | | | |
| number of poles of slip ring body including protective earth | | | | | | | | | | | |
| current rating of slip ring body (A) | | | | | | | | | | | |

In our offer text or confirmation of order, the type keys are written as follows
 LT220/251H4-26 or LTAI530/424-4-150

Selection of Drum Types

For the selection of a reeling drum, typical drum arrangement for the respective application (see page 4) and the intended cable coiling drum (type, cross-section, outside diameter and weight per meter of the cable) are decisive.

- | | |
|---|---|
| <p>l = operational maximum cable length that can be coiled (m)</p> <p>L = maximum cable length that hangs from the drum (m) ("L" can be equal to the cable length "l" that can be operationally coiled)</p> <p>h = maximum mounting height (m) = distance from cable fixed point up to drum middle (m). Measurement "h" can be fallen short of partially by considering sufficient floor clearance (e.g. for cable payout in a driving direction). For payout in two driving directions and overrunning the cable's fixed point, deflection and tension relief devices must be provided.</p> | <p>NL = number of layers of cable on the drum (partly decisive for determining cable cross-section)</p> <p>n_v = necessary drum pre-tension rotation</p> <p>n = operationally necessary and at the same time maximum permissible drum rotation for maximum length of cable that can be coiled "l"</p> <p>TF = max. tensile force for pulling the cable (N)</p> <p>f = max. cable dip (f) based on cable fixed point "LF"</p> |
|---|---|

Note

At the expense of a small coiling length, a higher starting pull n_{vU} can be achieved by greater initial stress.

The drum's total rotational speed $n_{vU} + n_U$ that is permissible for the springs may never be exceeded, since the danger exists that the spring may break.

- n_{vU} = rotational speed, pre-tension
 n_U = speed of rotation for cable



Arrangement Examples

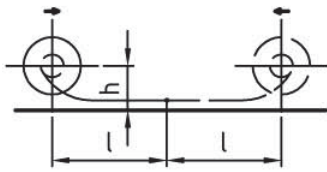

fig. A

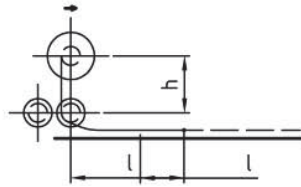

fig. B

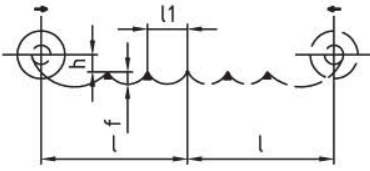

fig. C

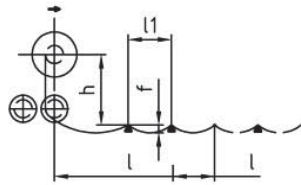

fig. D

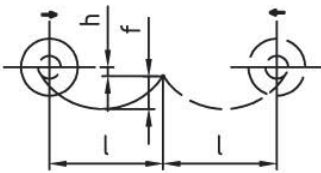

fig. E

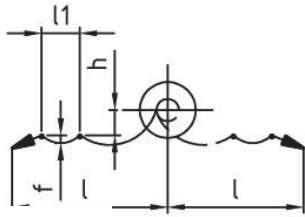

fig. F

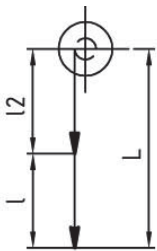

fig. G



fig. H

Figures A and B

Drum on mobile unit. Cable deposit on the ground or on a continuous surface. Horizontal cable payout is towards one or two sides.

Figure B via a deflector pulley.

Figures C and D

Drum on mobile unit. Cable deposit on supports for l_1 up to 1 m. For l above 1 m to max 3 m, the cable is kept on rollers or on smooth supports rounded upwards.

Figure D via a deflector pulley.

Figure E

Drum on mobile unit or on a fixed point. Horizontal cable payout is towards one or two sides. (f is dependent on cable cross-section and on tensile force).

Figure F

Drum is stationary. Horizontal cable payout towards one side or two sides, cable is deposited as above in figures C and D, however on rollers.

Figure G

Cable payout is vertical or approximately downwards.

l = lifting height or payout length

L = cable length = $l + l_2 + 2$ safety windings

Figure H

Cable payout is vertical, otherwise like figure G.



Spring Cable reeling Drums cylindrical, horizontal, v= 60 m/min

Type Series LT, LTAI, LTAII



Type Series LT

| 4 x 1.5 mm ² , Ø 11.1 mm, 0.16 kg/m, Tensile Force of Cable max. 1200 N | | | | | | | | |
|--|-------|-----|----------------|-------------|----|--------|-------|--------|
| l (m) | h (m) | NL | Type Series | Weight (kg) | A | nv.(U) | n.(U) | TF.(N) |
| 7 | 0.5 | 1.7 | LT155/108-4-26 | 3.1 | 26 | 2 | 13 | 40 |
| 12 | 0.5 | 2.0 | LT180/131-4-26 | 9.0 | 26 | 2 | 19 | 60 |
| 27 | 0.5 | 4.0 | LT180/231H4-26 | 11.0 | 26 | 4 | 38 | 60 |
| 38 | 1.0 | 5.0 | LT222/351H4-26 | 15.5 | 26 | 4 | 36 | 100 |
| 47 | 1.0 | 3.0 | LT300/252H4-26 | 28.0 | 26 | 4 | 45 | 100 |
| 72 | 1.0 | 4.0 | LT301/352H4-26 | 34.2 | 26 | 6 | 69 | 100 |
| 83 | 1.5 | 3.0 | LT420/253H4-36 | 56.0 | 36 | 4 | 58 | 120 |

| 5 x 1.5 mm ² , Ø 11.8 mm, 0.18 kg/m, Tensile Force of Cable max. 1500 N | | | | | | | | |
|--|-------|-----|----------------|-------------|----|--------|-------|--------|
| l (m) | h (m) | NL | Type Series | Weight (kg) | A | nv.(U) | n.(U) | TF.(N) |
| 7 | 0.5 | 1.7 | LT155/108-5-26 | 3.5 | 26 | 2 | 13 | 40 |
| 12 | 0.5 | 2.0 | LT180/131-5-26 | 9.0 | 26 | 2 | 19 | 60 |
| 20 | 0.5 | 4.0 | LT180/231H5-26 | 11.0 | 26 | 4 | 37 | 60 |
| 26 | 1.0 | 3.0 | LT220/251H5-26 | 19.0 | 26 | 4 | 33 | 100 |
| 39 | 1.0 | 4.0 | LT222/351H5-26 | 22.0 | 26 | 6 | 49 | 100 |
| 47 | 1.0 | 3.0 | LT300/252H5-26 | 28.0 | 26 | 4 | 45 | 100 |
| 73 | 1.0 | 4.0 | LT301/352H5-26 | 34.2 | 26 | 6 | 69 | 100 |
| 83 | 1.5 | 2.9 | LT420/253H5-36 | 56.0 | 36 | 4 | 58 | 120 |

| 7 x 1.5 mm ² , Ø 13.3 mm, 0.23 kg/m, Tensile Force of Cable max. 2000 N | | | | | | | | |
|--|-------|-----|----------------|-------------|----|--------|-------|--------|
| l (m) | h (m) | NL | Type Series | Weight (kg) | A | nv.(U) | n.(U) | TF.(N) |
| 7 | 0.5 | 1.9 | LT155/108-7-26 | 3.5 | 26 | 2 | 13 | 40 |
| 10 | 0.5 | 3.0 | LT180/131-7-26 | 10.5 | 26 | 2 | 16 | 60 |
| 12 | 1.0 | 3.0 | LT220/151-7-26 | 19.5 | 26 | 2 | 16.5 | 100 |
| 20 | 1.0 | 3.0 | LT220/251H7-26 | 21.5 | 26 | 4 | 25 | 100 |
| 41 | 1.0 | 5.0 | LT222/351H7-26 | 23.1 | 26 | 6 | 49 | 100 |
| 49 | 1.0 | 3.5 | LT300/252H7-26 | 28.0 | 26 | 4 | 45 | 100 |
| 73 | 1.0 | 4.0 | LT301/352H7-26 | 34.2 | 26 | 6 | 67 | 100 |
| 80 | 1.5 | 4.0 | LT420/253H7-36 | 57.0 | 36 | 4 | 57 | 120 |

| 12 x 1.5 mm ² , Ø 16.9 mm, 0.36 kg/m, Tensile Force of Cable max. 2500 N | | | | | | | | |
|---|-------|-----|-------------------|-------------|----|--------|-------|--------|
| l (m) | h (m) | NL | Type Series | Weight (kg) | A | nv.(U) | n.(U) | TF.(N) |
| 7 | 0.5 | 2.0 | LT180/131-12-26 | 10.5 | 26 | 2 | 12 | 60 |
| 9 | 1.0 | 2.0 | LT220/151-12-26 | 19.5 | 26 | 2 | 12 | 100 |
| 22 | 1.0 | 4.0 | LT220/251H12-26 | 22.5 | 26 | 2 | 30 | 100 |
| 32 | 1.0 | 3.0 | LT300/252H12-36 | 30.0 | 36 | 4 | 45 | 100 |
| 48 | 1.0 | 3.0 | LT301/352H12-36 | 39.0 | 36 | 6 | 62 | 100 |
| 56 | 1.5 | 4.0 | LT301/372H12-36 | 44.0 | 36 | 6 | 35 | 170 |
| 71 | 1.5 | 4.0 | LT420/283H12-36 | 57.0 | 36 | 4 | 49 | 120 |
| 79 | 1.5 | 4.0 | LT420/253H12-36 | 59.0 | 36 | 4 | 54 | 120 |
| 85 | 1.5 | 5.0 | LT421/253H12-36 | 63.0 | 36 | 4 | 57 | 120 |
| 106 | 1.5 | 3.5 | LTAI530/424-12-36 | 128.0 | 36 | 5 | 57 | 160 |

| 18 x 1.5 mm ² , Ø 17.9 mm, 0.47 kg/m, Tensile Force of Cable max. 2500 N | | | | | | | | |
|---|-------|-----|-----------------|-------------|----|--------|-------|--------|
| l (m) | h (m) | NL | Type Series | Weight (kg) | A | nv.(U) | n.(U) | TF.(N) |
| 11 | 1.0 | 2.5 | LT220/251-18-36 | 22.0 | 36 | 2 | 13 | 200 |
| 18 | 1.0 | 3.0 | LT221/251H18-36 | 25.0 | 36 | 4 | 22 | 100 |
| 23 | 1.0 | 3.0 | LT300/252-18-36 | 31.0 | 36 | 4 | 22.5 | 210 |
| 29 | 1.5 | 3.0 | LT300/272H18-36 | 38.0 | 36 | 4 | 28 | 180 |
| 33 | 1.5 | 3.0 | LT420/183-18-36 | 55.0 | 36 | 2 | 24 | 120 |
| 40 | 1.5 | 4.0 | LT420/153-18-36 | 56.0 | 36 | 2 | 29 | 120 |
| 73 | 1.5 | 4.0 | LT420/283H18-36 | 58.0 | 36 | 4 | 49 | 120 |
| 87 | 1.5 | 5.0 | LT421/253H18-36 | 61.0 | 36 | 4 | 57 | 120 |



Spring Cable reeling Drums cylindrical, horizontal, v= 60 m/min Type Series LT, LTAI, LTAII



Type Series LT

| 24 x 1.5 mm ² , Ø 22.6 mm, 0.59 kg/m, Tensile Force of Cable max. 2500 N | | | | | | | | |
|---|-------|-----|--------------------|-------------|----|--------|-------|--------|
| l (m) | h (m) | NL | Type Series | Weight (kg) | A | nv.(U) | n.(U) | TF.(N) |
| 14 | 1.0 | 2.0 | LT300/152-24-36 | 29.0 | 36 | 2 | 22 | 100 |
| 24 | 1.0 | 3.0 | LT300/252-24-36 | 31.0 | 36 | 2 | 22 | 210 |
| 35 | 1.5 | 3.0 | LT420/283-24-36 | 59.0 | 36 | 2 | 24 | 240 |
| 41 | 1.5 | 3.0 | LT420/253-24-36 | 61.0 | 36 | 2 | 28 | 240 |
| 45 | 1.5 | 3.1 | LT421/253-24-36 | 68.0 | 36 | 2 | 29 | 240 |
| 76 | 1.5 | 3.3 | LT530/286H24-36 | 117.0 | 36 | 4 | 40 | 245 |
| 89 | 1.5 | 3.8 | LTAII530/624-24-36 | 152.0 | 36 | 4 | 46 | 305 |

| 30 x 1.5 mm ² , Ø 24.2 mm, 0.71 kg/m, Tensile Force of Cable max. 2500 N | | | | | | | | |
|---|-------|-----|--------------------|-------------|----|--------|-------|--------|
| l (m) | h (m) | NL | Type Series | Weight (kg) | A | nv.(U) | n.(U) | TF.(N) |
| 20 | 1.0 | 2.0 | LT300/252-30-36 | 31.0 | 36 | 2 | 13 | 210 |
| 36 | 1.5 | 3.0 | LT420/283-30-36 | 60.0 | 36 | 2 | 24 | 240 |
| 38 | 1.5 | 3.0 | LT420/253-30-36 | 62.0 | 36 | 2 | 25 | 240 |
| 46 | 1.5 | 3.4 | LT421/253-30-36 | 68.0 | 36 | 2 | 29 | 240 |
| 78 | 1.5 | 3.6 | LT530/286H30-36 | 118.0 | 36 | 4 | 40 | 245 |
| 91 | 1.5 | 4.0 | LTAII530/624-30-36 | 152.0 | 36 | 4 | 46 | 305 |

| 4 x 2.5 mm ² , Ø 12.1 mm, 0.21 kg/m, Tensile Force of Cable max. 1600 N | | | | | | | | |
|--|-------|-----|------------------|-------------|----|--------|-------|--------|
| l (m) | h (m) | NL | Type Series | Weight (kg) | A | nv.(U) | n.(U) | TF.(N) |
| 5 | 0.5 | 2.0 | LT155/108-4-26 | 4.0 | 26 | 2 | 11.5 | 40 |
| 10 | 0.5 | 2.0 | LT180/131-4-26 | 9.0 | 26 | 2 | 18 | 60 |
| 12 | 0.5 | 4.0 | LT220/151-4-26 | 16.0 | 26 | 2 | 16.5 | 100 |
| 29 | 1.0 | 4.0 | LT220/251H4-26 | 19.5 | 26 | 4 | 34 | 100 |
| 42 | 1.0 | 4.0 | LT222/351H4-26 | 23.0 | 26 | 6 | 50 | 100 |
| 46 | 1.0 | 4.0 | LT300/252H4-26 | 25.0 | 26 | 4 | 45 | 100 |
| 68 | 1.0 | 4.0 | LT301/352H4-26 | 34.0 | 26 | 6 | 67 | 100 |
| 83 | 1.5 | 4.0 | LT420/253H4-36 | 56.0 | 36 | 4 | 58 | 120 |
| 88 | 1.5 | 3.0 | LT530/285H4-36 | 110.0 | 36 | 4 | 50 | 130 |
| 102 | 1.5 | 2.6 | LTAI530/324-4-36 | 116.0 | 36 | 5 | 58 | 120 |

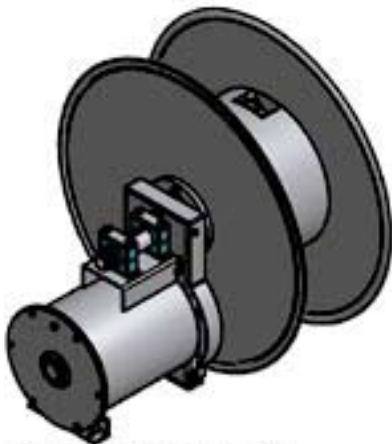

Type Series LTAI and LTAII

| 5 x 2.5 mm ² , Ø 12.8 mm, 0.24 kg/m, Tensile Force of Cable max. 1800 N | | | | | | | | |
|--|-------|-----|------------------|-------------|----|--------|-------|--------|
| l (m) | h (m) | NL | Type Series | Weight (kg) | A | nv.(U) | n.(U) | TF.(N) |
| 4 | 0.5 | 1.0 | LT155/108-5-26 | 6.0 | 26 | 2 | 8 | 40 |
| 11 | 0.5 | 2.0 | LT180/131-5-26 | 10.0 | 26 | 2 | 18 | 60 |
| 12 | 0.5 | 2.0 | LT220/151-5-26 | 16.0 | 26 | 2 | 16.5 | 100 |
| 26 | 1.0 | 2.9 | LT220/251H5-26 | 16.0 | 26 | 4 | 25 | 100 |
| 40 | 1.0 | 3.5 | LT222/351H5-26 | 18.5 | 26 | 6 | 33 | 100 |
| 46 | 1.0 | 4.0 | LT300/252H5-26 | 25.5 | 26 | 4 | 45 | 100 |
| 69 | 1.0 | 4.0 | LT301/352H5-26 | 28.0 | 26 | 6 | 67.5 | 100 |
| 80 | 1.5 | 3.5 | LT420/253H5-36 | 56.0 | 36 | 4 | 57 | 120 |
| 103 | 1.5 | 2.6 | LTAI530/324-5-36 | 116.0 | 36 | 6 | 58 | 120 |

| 7 x 2.5 mm ² , Ø 14.0 mm, 0.31 kg/m, Tensile Force of Cable max. 2500 N | | | | | | | | |
|--|-------|-----|------------------|-------------|----|--------|-------|--------|
| l (m) | h (m) | NL | Type Series | Weight (kg) | A | nv.(U) | n.(U) | TF.(N) |
| 10 | 0.5 | 2.0 | LT180/131-7-26 | 9.0 | 26 | 2 | 18 | 60 |
| 12 | 0.5 | 3.0 | LT220/151-7-26 | 15.5 | 26 | 2 | 16.5 | 100 |
| 17 | 1.0 | 3.0 | LT220/251H7-26 | 19.0 | 26 | 4 | 33 | 100 |
| 26 | 1.0 | 4.0 | LT221/251H7-26 | 20.0 | 26 | 4 | 33 | 100 |
| 41 | 1.0 | 5.0 | LT222/351H7-26 | 21.0 | 26 | 6 | 49 | 100 |
| 47 | 1.0 | 4.0 | LT300/252H7-26 | 29.0 | 26 | 4 | 45 | 100 |
| 71 | 1.0 | 4.0 | LT301/352H7-26 | 35.0 | 26 | 6 | 67 | 100 |
| 81 | 1.5 | 4.0 | LT420/253H7-36 | 55.0 | 36 | 4 | 57 | 120 |
| 104 | 1.5 | 2.9 | LTAI530/424-7-36 | 129.0 | 36 | 5 | 58 | 160 |



Spring Cable reeling Drums cylindrical, horizontal, v= 60 m/min Type Series LT, LTAI, LTAII



Type Series LT

| 12 x 2.5 mm ² , Ø 20.2 mm, 0.48 kg/m, Tensile Force of Cable max. 2500 N | | | | | | | | |
|---|-------|-----|--------------------|-------------|----|--------|-------|--------|
| l (m) | h (m) | NL | Type Series | Weight (kg) | A | nv.(U) | n.(U) | TF.(N) |
| 16 | 1.0 | 2.0 | LT300/152-12-36 | 28.0 | 36 | 2 | 22 | 100 |
| 25 | 1.0 | 2.7 | LT300/252-12-36 | 30.0 | 36 | 2 | 22 | 210 |
| 29 | 1.0 | 4.0 | LT301/372H12-36 | 34.0 | 36 | 6 | 52 | 100 |
| 34 | 1.5 | 3.0 | LT420/183-12-36 | 53.0 | 36 | 2 | 24 | 120 |
| 41 | 1.5 | 2.8 | LT420/153-12-36 | 55.0 | 36 | 2 | 28 | 120 |
| 83 | 1.5 | 5.0 | LT421/253H12-36 | 60.0 | 36 | 4 | 57 | 120 |
| 85 | 1.5 | 5.0 | LT530/285H12-36 | 66.0 | 36 | 4 | 57 | 200 |
| 107 | 1.5 | 4.0 | LTAII530/524-12-36 | 142.0 | 36 | 5 | 56 | 200 |

| 18 x 2.5 mm ² , Ø 20.6 mm, 0.68 kg/m, Tensile Force of Cable max. 2500 N | | | | | | | | |
|---|-------|-----|--------------------|-------------|----|--------|-------|--------|
| l (m) | h (m) | NL | Type Series | Weight (kg) | A | nv.(U) | n.(U) | TF.(N) |
| 15 | 1.0 | 2.0 | LT300/152-18-36 | 29.0 | 36 | 2 | 22 | 100 |
| 24 | 1.0 | 3.0 | LT300/252-18-36 | 32.0 | 36 | 2 | 22 | 210 |
| 27 | 1.0 | 3.0 | LT300/272H18-36 | 36.0 | 36 | 4 | 35 | 170 |
| 34 | 1.5 | 3.0 | LT420/283-18-36 | 58.0 | 36 | 2 | 24 | 240 |
| 45 | 1.5 | 3.0 | LT420/253H18-36 | 60.0 | 36 | 4 | 57 | 120 |
| 69 | 1.5 | 3.0 | LT530/286H18-36 | 65.0 | 36 | 4 | 40 | 245 |
| 87 | 1.5 | 3.4 | LTAI530/424-18-36 | 140.0 | 36 | 4 | 46 | 200 |
| 104 | 1.5 | 4.0 | LTAII530/524-18-36 | 150.0 | 36 | 5 | 54 | 200 |

| 24 x 2.5 mm ² , Ø 25.5 mm, 0.82 kg/m, Tensile Force of Cable max. 2500 N | | | | | | | | |
|---|-------|-----|--------------------|-------------|----|--------|-------|--------|
| l (m) | h (m) | NL | Type Series | Weight (kg) | A | nv.(U) | n.(U) | TF.(N) |
| 12 | 1.0 | 2.0 | LT300/172-24-36 | 35.0 | 36 | 2 | 19 | 165 |
| 22 | 1.0 | 3.0 | LT300/272-24-36 | 35.0 | 36 | 2 | 19 | 330 |
| 36 | 1.5 | 3.0 | LT421/283-24-36 | 63.0 | 36 | 2 | 24 | 240 |
| 43 | 1.5 | 3.6 | LT421/253-24-36 | 70.0 | 36 | 2 | 29 | 240 |
| 79 | 1.5 | 3.8 | LT530/286H24-36 | 133.0 | 36 | 4 | 40 | 245 |
| 88 | 1.5 | 4.0 | LTAII530/525-24-36 | 144.0 | 36 | 5 | 44 | 300 |

| 30 x 2.5 mm ² , Ø 28.7 mm, 0.97 kg/m, Tensile Force of Cable max. 2500 N | | | | | | | | |
|---|-------|-----|--------------------|-------------|----|--------|-------|--------|
| l (m) | h (m) | NL | Type Series | Weight (kg) | A | nv.(U) | n.(U) | TF.(N) |
| 8 | 1.5 | 1.0 | LT420/183-30-36 | 68.0 | 36 | 2 | 24 | 120 |
| 20 | 1.5 | 2.0 | LT420/283-30-36 | 68.0 | 36 | 2 | 24 | 240 |
| 33 | 1.5 | 4.0 | LT421/253-30-36 | 75.0 | 36 | 2 | 28 | 240 |
| 77 | 1.5 | 4.0 | LT530/286H30-36 | 135.5 | 36 | 4 | 38 | 245 |
| 98 | 1.5 | 3.6 | LTAII700/625-30-36 | 238.0 | 36 | 4 | 39 | 340 |

| 4 x 4 mm ² , Ø 13.4 mm, 0.28 kg/m, Tensile Force of Cable max. 1800 N | | | | | | | | |
|--|-------|-----|------------------|-------------|----|--------|-------|--------|
| l (m) | h (m) | NL | Type Series | Weight (kg) | A | nv.(U) | n.(U) | TF.(N) |
| 9 | 0.5 | 2.0 | LT180/131-4-40 | 8.5 | 40 | 2 | 18 | 60 |
| 12 | 0.5 | 3.0 | LT220/151-4-40 | 18.0 | 40 | 2 | 25 | 100 |
| 16 | 1.0 | 3.0 | LT220/251H4-40 | 20.0 | 40 | 4 | 33 | 100 |
| 26 | 1.0 | 4.0 | LT221/251H4-40 | 22.0 | 40 | 4 | 33 | 100 |
| 41 | 1.0 | 5.0 | LT222/351H4-40 | 23.1 | 40 | 6 | 46 | 100 |
| 47 | 1.0 | 4.0 | LT300/252H4-40 | 31.0 | 40 | 4 | 45 | 100 |
| 73 | 1.0 | 3.5 | LT301/352H4-40 | 37.0 | 40 | 6 | 67 | 100 |
| 81 | 1.5 | 4.0 | LT420/253H4-42 | 55.0 | 42 | 4 | 58 | 120 |
| 103 | 1.5 | 2.7 | LTAI530/424-4-42 | 156.0 | 42 | 5 | 58 | 160 |

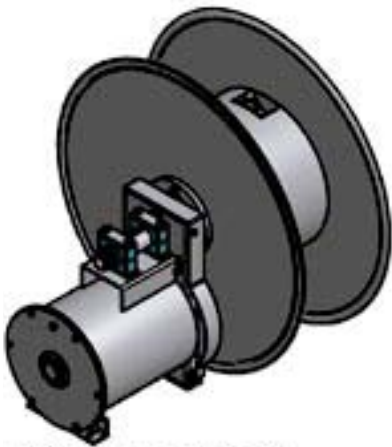

Type Series LTAI and LTAII



Spring Cable reeling Drums cylindrical, horizontal, v= 60 m/min Type Series LT, LTAI, LTAII



Type Series LT

| 5 x 4 mm ² , Ø 14.5 mm, 0.32 kg/m, Tensile Force of Cable max. 2000 N | | | | | | | | | |
|--|-------|-----|------------------|-------------|----|--------|-------|--------|--|
| l (m) | h (m) | NL | Type Series | Weight (kg) | A | nv.(U) | n.(U) | TF.(N) | |
| 4 | 0.5 | 1.0 | LT180/131-5-40 | 7.8 | 40 | 2 | 18 | 60 | |
| 9 | 0.5 | 2.0 | LT180/231-5-40 | 8.5 | 40 | 2 | 18 | 120 | |
| 12 | 0.5 | 3.0 | LT220/151-5-40 | 17.5 | 40 | 2 | 16 | 100 | |
| 26 | 1.0 | 4.0 | LT221/251H5-40 | 21.0 | 40 | 4 | 33 | 100 | |
| 41 | 1.0 | 5.0 | LT222/351H5-40 | 24.0 | 40 | 6 | 49 | 100 | |
| 50 | 1.0 | 3.9 | LT300/252H5-40 | 28.0 | 40 | 4 | 45 | 100 | |
| 70 | 1.0 | 4.0 | LT301/352H5-40 | 36.5 | 40 | 6 | 67 | 100 | |
| 81 | 1.5 | 4.0 | LT420/253H5-42 | 55.5 | 42 | 4 | 57 | 120 | |
| 104 | 1.5 | 3.0 | LTAI530/424-5-42 | 156.0 | 42 | 5 | 58 | 160 | |

| 4 x 6 mm ² , Ø 14.8 mm, 0.37 kg/m, Tensile Force of Cable max. 2000 N | | | | | | | | | |
|--|-------|-----|------------------|-------------|----|--------|-------|--------|--|
| l (m) | h (m) | NL | Type Series | Weight (kg) | A | nv.(U) | n.(U) | TF.(N) | |
| 12 | 1.0 | 3.0 | LT220/151-4-60 | 16.0 | 60 | 2 | 18 | 100 | |
| 17 | 1.0 | 3.0 | LT220/251H4-60 | 18.0 | 60 | 4 | 33 | 100 | |
| 26 | 1.0 | 4.0 | LT221/251H4-60 | 20.0 | 60 | 4 | 33 | 100 | |
| 50 | 1.0 | 3.9 | LT300/252H4-60 | 31.0 | 60 | 4 | 45 | 100 | |
| 57 | 1.0 | 4.0 | LT301/352H4-60 | 37.0 | 60 | 6 | 55 | 100 | |
| 69 | 1.5 | 4.0 | LT420/283H4-60 | 54.0 | 60 | 4 | 48 | 120 | |
| 82 | 1.5 | 4.0 | LT420/253H4-60 | 56.0 | 60 | 4 | 57 | 120 | |
| 105 | 1.5 | 3.1 | LTAI530/424-4-60 | 156.0 | 60 | 5 | 58 | 180 | |

| 5 x 6 mm ² , Ø 16.1 mm, 0.43 kg/m, Tensile Force of Cable max. 2500 N | | | | | | | | | |
|--|-------|-----|-------------------|-------------|----|--------|-------|--------|--|
| l (m) | h (m) | NL | Type Series | Weight (kg) | A | nv.(U) | n.(U) | TF.(N) | |
| 9 | 1.0 | 2.9 | LT220/151-5-60 | 19.1 | 60 | 2 | 16 | 100 | |
| 12 | 1.0 | 3.0 | LT221/151-5-60 | 20.0 | 60 | 2 | 16 | 100 | |
| 27 | 1.0 | 4.0 | LT221/251H5-60 | 20.5 | 60 | 4 | 33 | 100 | |
| 32 | 1.0 | 4.0 | LT222/351H5-60 | 24.0 | 60 | 6 | 48 | 100 | |
| 37 | 1.0 | 4.0 | LT300/272H5-60 | 30.0 | 60 | 4 | 35 | 170 | |
| 55 | 1.0 | 4.0 | LT301/372H5-60 | 36.0 | 60 | 6 | 52 | 170 | |
| 71 | 1.5 | 4.0 | LT420/283H5-60 | 55.0 | 60 | 4 | 49 | 120 | |
| 84 | 1.5 | 5.0 | LT420/253H5-60 | 57.0 | 60 | 4 | 57 | 120 | |
| 106 | 1.5 | 3.3 | LTAII530/524-5-60 | 168.0 | 60 | 5 | 58 | 200 | |

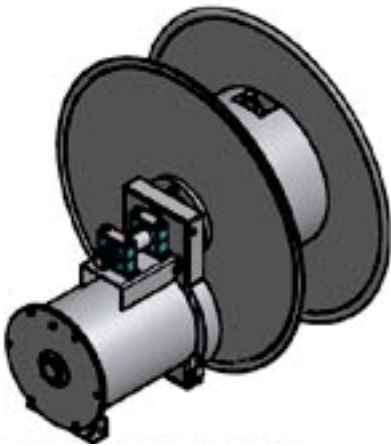

Type Series LTAI and LTAII

| 4 x 10 mm ² , Ø 18.8 mm, 0.61 kg/m, Tensile Force of Cable max. 2000 N | | | | | | | | | |
|---|-------|-----|-------------------|-------------|----|--------|-------|--------|--|
| l (m) | h (m) | NL | Type Series | Weight (kg) | A | nv.(U) | n.(U) | TF.(N) | |
| 7 | 1.0 | 2.0 | LT220/151-4-60 | 19.0 | 60 | 2 | 16 | 100 | |
| 13 | 1.0 | 3.0 | LT220/251-4-60 | 21.0 | 60 | 2 | 16 | 200 | |
| 17 | 1.0 | 2.0 | LT300/172-4-60 | 26.0 | 60 | 2 | 17 | 170 | |
| 23 | 1.0 | 3.0 | LT300/252-4-60 | 28.0 | 60 | 2 | 22 | 200 | |
| 29 | 1.0 | 3.0 | LT300/272H4-60 | 30.0 | 60 | 4 | 34 | 170 | |
| 34 | 1.5 | 4.0 | LT420/283-4-60 | 55.0 | 60 | 2 | 23 | 240 | |
| 40 | 1.5 | 3.0 | LT420/253-4-60 | 57.0 | 60 | 2 | 28 | 240 | |
| 45 | 1.5 | 3.0 | LT420/284H4-60 | 59.0 | 60 | 4 | 32 | 235 | |
| 68 | 1.5 | 3.0 | LT530/286H4-60 | 131.0 | 60 | 4 | 40 | 245 | |
| 85 | 1.5 | 4.0 | LTAI530/424-4-60 | 156.0 | 60 | 4 | 46 | 200 | |
| 110 | 1.5 | 3.9 | LTAII530/524-4-60 | 168.0 | 60 | 5 | 58 | 200 | |



Spring Cable reeling Drums cylindrical, horizontal, v= 60 m/min Type Series LT, LTAI, LTAII



Type Series LT

| 4 x 16 mm ² , Ø 23.4 mm, 0.92 kg/m, Tensile Force of Cable max. 2500 N | | | | | | | | | |
|---|-------|-----|-------------------|-------------|-----|--------|-------|--------|--|
| l (m) | h (m) | NL | Type Series | Weight (kg) | A | nv.(U) | n.(U) | TF.(N) | |
| 14 | 1.0 | 3.0 | LT300/152-4-125 | 25.0 | 125 | 2 | 15 | 100 | |
| 18 | 1.0 | 3.0 | LT300/272-4-125 | 28.0 | 125 | 2 | 19 | 330 | |
| 25 | 1.0 | 2.0 | LT420/283-4-150 | 58.0 | 150 | 2 | 24 | 240 | |
| 35 | 1.5 | 2.0 | LT421/283-4-150 | 60.0 | 150 | 2 | 24 | 240 | |
| 42 | 1.5 | 4.0 | LT421/253-4-150 | 62.0 | 150 | 2 | 28 | 240 | |
| 71 | 1.5 | 4.0 | LT530/286H4-150 | 131.0 | 150 | 4 | 40 | 245 | |
| 90 | 1.5 | 3.9 | LTAI530/424-4-150 | 156.0 | 150 | 4 | 46 | 200 | |

| 4 x 25 mm ² , Ø 27.1 mm, 1.27 kg/m, Tensile Force of Cable max. 2500 N | | | | | | | | | |
|---|-------|-----|--------------------|-------------|-----|--------|-------|--------|--|
| l (m) | h (m) | NL | Type Series | Weight (kg) | A | nv.(U) | n.(U) | TF.(N) | |
| 15 | 1.5 | 2.0 | LT420/283-4-150 | 58.0 | 150 | 2 | 14 | 240 | |
| 20 | 1.5 | 2.0 | LT420/184-4-150 | 58.0 | 150 | 2 | 16 | 230 | |
| 33 | 1.5 | 3.0 | LT421/283-4-150 | 60.0 | 150 | 2 | 25 | 240 | |
| 42 | 1.5 | 2.6 | LT530/285-4-150 | 112.0 | 150 | 2 | 25 | 260 | |
| 80 | 1.5 | 4.0 | LTAI530/424-4-150 | 138.0 | 150 | 4 | 46 | 200 | |
| 117 | 1.5 | 4.0 | LTAII700/624-4-150 | 240.0 | 150 | 4 | 46 | 230 | |

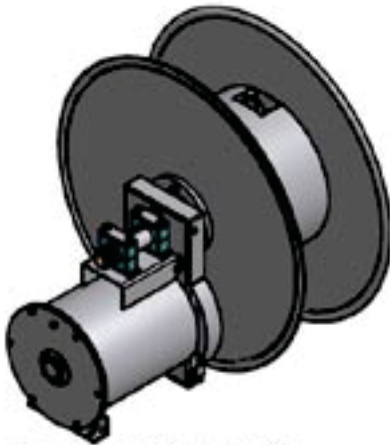

Type Series LTAI and LTAII

| 4 x 35 mm ² , Ø 29.7 mm, 1.72 kg/m, Tensile Force of Cable max. 2500 N | | | | | | | | | |
|---|-------|-----|-------------------|-------------|-----|--------|-------|--------|--|
| l (m) | h (m) | NL | Type Series | Weight (kg) | A | nv.(U) | n.(U) | TF.(N) | |
| 8 | 1.5 | 1.0 | LT420/183-4-150 | 55.0 | 150 | 2 | 8 | 120 | |
| 20 | 1.5 | 2.0 | LT420/283-4-150 | 58.0 | 150 | 2 | 15 | 240 | |
| 31 | 1.5 | 2.0 | LT530/186-4-150 | 111.0 | 150 | 2 | 19 | 245 | |
| 49 | 1.5 | 2.8 | LT530/285-4-150 | 112.0 | 150 | 2 | 25 | 265 | |
| 100 | 1.5 | 3.7 | LTAI700/425-4-150 | 188.0 | 150 | 4 | 39 | 230 | |

| 4 x 50 mm ² , Ø= 35.1 mm, 2.63 kg/m, Tensile Force of Cable max. 3000 N | | | | | | | | | |
|--|-------|-----|--------------------|-------------|-----|--------|-------|--------|--|
| l (m) | h (m) | NL | Type Series | Weight (kg) | A | nv.(U) | n.(U) | TF.(N) | |
| 42 | 1.5 | 2.9 | LT530/286-4-220 | 131.0 | 220 | 2 | 21 | 490 | |
| 75 | 1.5 | 3.4 | LTAII700/625-4-220 | 255.0 | 220 | 3 | 29 | 455 | |



Spring Cable reeling Drums, cylindrical, horizontal freely suspended, v= 60 m/min Type Series LT, LTAI, LTAII



Type Series LT

| 4 x 1.5 mm ² , Ø= 11.1 mm, 0.16 kg/m, Tensile Force of Cable max. 1200 N | | | | | | | | | |
|---|-------|---------|-----|----------------|-------------|----|--------|-------|--------|
| l (m) | h (m) | f1* (m) | NL | Type Series | Weight (kg) | A | nv.(U) | n.(U) | TF.(N) |
| 7 | 1.0 | 0.5 | 1.7 | LT155/108-4-26 | 3.1 | 26 | 2 | 13 | 40 |
| 9 | 1.0 | 0.5 | 2.0 | LT155/208H4-26 | 3.7 | 26 | 14 | 16 | 40 |
| 12 | 1.0 | 0.6 | 1.9 | LT180/231-4-26 | 9.0 | 26 | 2 | 19 | 60 |
| 22 | 1.5 | 1.0 | 3.0 | LT220/251H4-26 | 19.0 | 26 | 4 | 31 | 100 |
| 30 | 1.5 | 1.1 | 2.0 | LT300/272H4-26 | 52.0 | 26 | 12 | 30 | 165 |
| 35 | 1.5 | 1.0 | 1.4 | LT420/283-4-36 | 56.0 | 36 | 2 | 25 | 240 |
| 40 | 1.5 | 1.2 | 1.0 | LT530/285-4-36 | 110.0 | 36 | 3 | 24 | 260 |

| 5 x 1.5 mm ² , Ø= 11.8 mm, 0.18 kg/m, Tensile Force of Cable max. 1500 N | | | | | | | | | |
|---|-------|---------|-----|----------------|-------------|----|--------|-------|--------|
| l (m) | h (m) | f1* (m) | NL | Type Series | Weight (kg) | A | nv.(U) | n.(U) | TF.(N) |
| 7 | 1.0 | 0.5 | 1.7 | LT155/108-5-26 | 3.1 | 26 | 2 | 13 | 40 |
| 8 | 1.0 | 0.7 | 2.0 | LT155/208H5-26 | 3.7 | 26 | 10 | 15 | 40 |
| 12 | 0.5 | 0.4 | 2.1 | LT180/231-5-26 | 11.5 | 26 | 2 | 19 | 120 |
| 16 | 0.5 | 0.3 | 2.4 | LT220/251-5-26 | 19.0 | 26 | 2 | 18 | 200 |
| 28 | 1.5 | 1.1 | 2.0 | LT300/272H5-26 | 52.0 | 26 | 11 | 28 | 165 |
| 34 | 1.5 | 1.0 | 1.4 | LT420/283-5-36 | 56.0 | 36 | 2 | 24 | 240 |
| 37 | 1.5 | 1.2 | 1.0 | LT530/285-5-36 | 110.0 | 36 | 3 | 22 | 260 |

| 7 x 1.5 mm ² , Ø= 13.3 mm, 0.23 kg/m, Tensile Force of Cable max. 2000 N | | | | | | | | | |
|---|-------|---------|-----|----------------|-------------|----|--------|-------|--------|
| l (m) | h (m) | f1* (m) | NL | Type Series | Weight (kg) | A | nv.(U) | n.(U) | TF.(N) |
| 7 | 0.5 | 0.2 | 1.8 | LT155/108-7-26 | 3.1 | 26 | 2 | 13 | 40 |
| 22 | 1.0 | 0.7 | 1.8 | LT300/252-7-26 | 29.0 | 26 | 2 | 22 | 210 |
| 35 | 2.0 | 1.5 | 1.6 | LT420/253-7-36 | 57.0 | 36 | 6 | 25 | 240 |
| 43 | 2.0 | 1.5 | 1.2 | LT530/285-7-36 | 111.0 | 36 | 2 | 25 | 260 |

| 12 x 1.5 mm ² , Ø= 16.9 mm, 0.36 kg/m, Tensile Force of Cable max. 1500 N | | | | | | | | | |
|--|-------|---------|-----|--------------------|-------------|----|--------|-------|--------|
| l (m) | h (m) | f1* (m) | NL | Type Series | Weight (kg) | A | nv.(U) | n.(U) | TF.(N) |
| 9 | 1.0 | 0.5 | 2.0 | LT220/151-12-26 | 19.5 | 26 | 2 | 12 | 100 |
| 20 | 1.5 | 0.9 | 2.0 | LT300/252-12-26 | 30.0 | 26 | 3 | 19 | 210 |
| 28 | 2.0 | 1.5 | 1.6 | LT420/283-12-36 | 58.0 | 36 | 5 | 20 | 240 |
| 34 | 1.5 | 1.1 | 1.3 | LT530/286-12-36 | 132.0 | 36 | 2 | 20 | 490 |
| 40 | 2.0 | 1.7 | 1.8 | LTAII530/525-12-36 | 150.0 | 36 | 15 | 23 | 430 |



Type Series LTAI and LTAII

| 18 x 1.5 mm ² , Ø= 17.9 mm, 0.47 kg/m, Tensile Force of Cable max. 2500 N | | | | | | | | | |
|--|-------|---------|-----|--------------------|-------------|----|--------|-------|--------|
| l (m) | h (m) | f1* (m) | NL | Type Series | Weight (kg) | A | nv.(U) | n.(U) | TF.(N) |
| 15 | 1.0 | 0.7 | 2.7 | LT221/251-18-36 | 25.0 | 36 | 2 | 18 | 200 |
| 19 | 1.5 | 1.0 | 2.0 | LT300/252-18-36 | 30.0 | 36 | 5 | 18 | 210 |
| 25 | 2.0 | 1.5 | 1.6 | LT420/283-18-36 | 58.0 | 36 | 6 | 18 | 240 |
| 32 | 2.0 | 1.3 | 1.3 | LT530/286-18-36 | 132.0 | 36 | 3 | 19 | 490 |
| 36 | 2.0 | 1.5 | 1.4 | LTAII530/525-18-36 | 150.0 | 36 | 12 | 21 | 500 |

| 24 x 1.5 mm ² , Ø= 22.6 mm, 0.59 kg/m, Tensile Force of Cable max. 2500 N | | | | | | | | | |
|--|-------|---------|-----|--------------------|-------------|----|--------|-------|--------|
| l (m) | h (m) | f1* (m) | NL | Type Series | Weight (kg) | A | nv.(U) | n.(U) | TF.(N) |
| 17 | 1.5 | 1.0 | 2.1 | LT300/252-24-36 | 31.0 | 36 | 7 | 15 | 210 |
| 22 | 2.0 | 1.5 | 1.7 | LT420/283-24-36 | 63.0 | 36 | 10 | 15 | 240 |
| 32 | 2.0 | 1.6 | 1.5 | LT530/286-24-36 | 133.0 | 36 | 2 | 18 | 490 |
| 40 | 2.0 | 1.7 | 1.8 | LTAII530/625-24-36 | 155.0 | 36 | 5 | 22 | 720 |

| 30 x 1.5 mm ² , Ø= 24.2 mm, 0.71 kg/m, Tensile Force of Cable max. 2500 N | | | | | | | | | |
|--|-------|---------|-----|--------------------|-------------|----|--------|-------|--------|
| l (m) | h (m) | f1* (m) | NL | Type Series | Weight (kg) | A | nv.(U) | n.(U) | TF.(N) |
| 15 | 1.5 | 1.0 | 2.1 | LT300/252-30-36 | 31.0 | 36 | 9 | 13 | 210 |
| 20 | 2.0 | 1.5 | 1.8 | LT420/283-30-36 | 63.0 | 36 | 11 | 14 | 240 |
| 30 | 2.0 | 1.6 | 1.3 | LT530/286-30-36 | 118.0 | 36 | 5 | 17 | 490 |
| 35 | 2.5 | 1.5 | 1.8 | LTAII530/625-30-36 | 155.0 | 36 | 7 | 20 | 720 |



Spring Cable reeling Drums, cylindrical, horizontal freely suspended, v= 60 m/min Type Series LT, LTAI, LTAII



Type Series LT

| 4 x 2.5 mm ² , Ø= 12.1 mm, 0.21 kg/m, Tensile Force of Cable max. 1600 N | | | | | | | | | |
|---|-------|---------|-----|------------------|-------------|----|--------|-------|--------|
| l (m) | h (m) | f1* (m) | NL | Type Series | Weight (kg) | A | nv.(U) | n.(U) | TF.(N) |
| 7 | 1.0 | 0.5 | 2.0 | LT155/108-4-26 | 3.1 | 26 | 2 | 13 | 40 |
| 14 | 0.5 | 0.3 | 2.2 | LT220/251-4-26 | 19.5 | 26 | 2 | 18 | 200 |
| 25 | 1.5 | 1.0 | 1.9 | LT300/272H4-26 | 52.0 | 26 | 17 | 25 | 165 |
| 33 | 1.5 | 1.2 | 1.4 | LT420/283-4-36 | 56.0 | 36 | 3 | 24 | 240 |
| 37 | 2.0 | 1.4 | 1.0 | LT530/285-4-36 | 110.0 | 36 | 5 | 22 | 265 |
| 46 | 2.0 | 1.4 | 1.2 | LTAI530/425-4-36 | 116.0 | 36 | 6 | 27 | 400 |

| 5 x 2.5 mm ² , Ø= 12.8 mm, 0.24 kg/m, Tensile Force of Cable max. 1800 N | | | | | | | | | |
|---|-------|---------|-----|------------------|-------------|----|--------|-------|--------|
| l (m) | h (m) | f1* (m) | NL | Type Series | Weight (kg) | A | nv.(U) | n.(U) | TF.(N) |
| 7 | 1.0 | 0.5 | 1.9 | LT155/108-5-26 | 3.1 | 26 | 2 | 13 | 40 |
| 14 | 0.5 | 0.3 | 2.2 | LT220/251-5-26 | 19.5 | 26 | 2 | 18 | 200 |
| 22 | 1.0 | 0.7 | 1.7 | LT300/252-5-26 | 31.0 | 26 | 2 | 22 | 210 |
| 25 | 1.5 | 1.1 | 1.9 | LT300/272H5-26 | 52.0 | 26 | 17 | 25 | 165 |
| 30 | 1.5 | 1.1 | 1.4 | LT420/283-5-36 | 56.0 | 36 | 5 | 22 | 240 |
| 37 | 2.0 | 1.5 | 1.1 | LT530/285-5-36 | 110.0 | 36 | 5 | 22 | 267 |
| 46 | 2.0 | 1.6 | 1.2 | LTAI530/425-5-36 | 116.0 | 36 | 7 | 26 | 400 |

| 7 x 2.5 mm ² , Ø= 14.0 mm, 0.31 kg/m, Tensile Force of Cable max. 2500 N | | | | | | | | | |
|---|-------|---------|-----|-------------------|-------------|----|--------|-------|--------|
| l (m) | h (m) | f1* (m) | NL | Type Series | Weight (kg) | A | nv.(U) | n.(U) | TF.(N) |
| 12 | 1.0 | 0.6 | 2.6 | LT181/231-7-26 | 11.5 | 26 | 2 | 19 | 120 |
| 14 | 1.0 | 0.4 | 2.5 | LT220/251-7-26 | 20.0 | 26 | 2 | 18 | 200 |
| 22 | 1.5 | 0.9 | 1.9 | LT300/252-7-26 | 31.0 | 26 | 2 | 22 | 210 |
| 26 | 2.0 | 1.6 | 2.2 | LT300/272H7-26 | 52.0 | 26 | 17 | 25 | 165 |
| 31 | 2.0 | 1.6 | 1.6 | LT420/283-7-36 | 57.0 | 36 | 4 | 23 | 240 |
| 34 | 2.0 | 1.7 | 1.1 | LT530/285-7-36 | 110.0 | 36 | 7 | 20 | 267 |
| 40 | 2.0 | 1.6 | 1.2 | LTAI530/425-7-36 | 116.0 | 36 | 10 | 23 | 400 |
| 45 | 2.0 | 1.6 | 1.3 | LTAII530/525-7-36 | 130.5 | 36 | 7 | 26 | 500 |

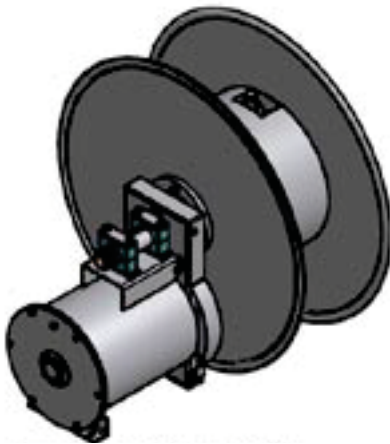

Type Series LTAI and LTAII

| 12 x 2.5 mm ² , Ø= 20.2 mm, 0.48 kg/m, Tensile Force of Cable max. 2500 N | | | | | | | | | |
|--|-------|---------|-----|--------------------|-------------|----|--------|-------|--------|
| l (m) | h (m) | f1* (m) | NL | Type Series | Weight (kg) | A | nv.(U) | n.(U) | TF.(N) |
| 20 | 1.5 | 1.1 | 2.4 | LT300/252-12-36 | 30.0 | 36 | 6 | 18 | 210 |
| 25 | 2.0 | 1.6 | 1.7 | LT300/272-12-36 | 58.0 | 36 | 10 | 17 | 240 |
| 35 | 2.0 | 1.5 | 1.5 | LT530/286-12-36 | 132.0 | 36 | 2 | 20 | 490 |
| 40 | 2.0 | 1.6 | 1.7 | LTAII530/525-12-36 | 130.5 | 36 | 4 | 23 | 600 |
| 43 | 2.0 | 1.6 | 1.8 | LTAII530/625-12-36 | 145.0 | 36 | 3 | 24 | 720 |

| 18 x 2.5 mm ² , Ø= 20.6 mm, 0.68 kg/m, Tensile Force of Cable max. 2500 N | | | | | | | | | |
|--|-------|---------|-----|--------------------|-------------|----|--------|-------|--------|
| l (m) | h (m) | f1* (m) | NL | Type Series | Weight (kg) | A | nv.(U) | n.(U) | TF.(N) |
| 18 | 2.0 | 1.3 | 2.2 | LT300/252-18-36 | 31.0 | 36 | 7 | 17 | 210 |
| 21 | 1.5 | 1.2 | 2.5 | LT300/272-18-36 | 52.0 | 36 | 2 | 19 | 230 |
| 30 | 2.0 | 1.6 | 1.4 | LT530/286-18-36 | 132.0 | 36 | 5 | 17 | 490 |
| 35 | 2.0 | 1.7 | 1.5 | LTAII530/525-18-36 | 130.5 | 36 | 7 | 20 | 600 |
| 38 | 2.5 | 1.7 | 1.7 | LTAII530/625-18-36 | 145.0 | 36 | 5 | 22 | 720 |

| 24 x 2.5 mm ² , Ø= 25.5 mm, 0.82 kg/m, Tensile Force of Cable max. 2500 N | | | | | | | | | |
|--|-------|---------|-----|--------------------|-------------|----|--------|-------|--------|
| l (m) | h (m) | f1* (m) | NL | Type Series | Weight (kg) | A | nv.(U) | n.(U) | TF.(N) |
| 20 | 2.5 | 1.7 | 1.8 | LT420/283-24-36 | 65.0 | 36 | 12 | 14 | 240 |
| 28 | 2.5 | 1.6 | 1.6 | LT530/286-24-36 | 133.0 | 36 | 6 | 16 | 490 |
| 31 | 2.5 | 1.7 | 1.7 | LTAII530/525-24-36 | 131.5 | 36 | 9 | 18 | 600 |
| 34 | 2.5 | 1.7 | 1.8 | LTAII530/625-24-36 | 147.0 | 36 | 8 | 19 | 720 |



Spring Cable reeling Drums, cylindrical, horizontal freely suspended, v= 60 m/min Type Series LT, LTAI, LTAII



Type Series LT

| 30 x 2.5 mm ² , Ø= 28.7 mm, 0.97 kg/m, Tensile Force of Cable max. 2500 N | | | | | | | | | |
|--|-------|---------|-----|--------------------|-------------|----|--------|-------|--------|
| l (m) | h (m) | f1* (m) | NL | Type Series | Weight (kg) | A | nv.(U) | n.(U) | TF.(N) |
| 18 | 2.5 | 1.7 | 1.9 | LT420/283-30-36 | 70.0 | 36 | 14 | 12 | 240 |
| 26 | 2.5 | 1.7 | 1.6 | LT530/286-30-36 | 135.5 | 36 | 7 | 14 | 490 |
| 32 | 2.5 | 1.7 | 2.0 | LTAII530/625-30-36 | 147.0 | 36 | 9 | 18 | 720 |

| 4 x 4 mm ² , Ø= 13.4 mm, 0.28 kg/m, Tensile Force of Cable max. 1800 N | | | | | | | | | |
|---|-------|---------|-----|-------------------|-------------|----|--------|-------|--------|
| l (m) | h (m) | f1* (m) | NL | Type Series | Weight (kg) | A | nv.(U) | n.(U) | TF.(N) |
| 7 | 1.0 | 0.5 | 2.0 | LT155/108-4-40 | 3.1 | 40 | 2 | 13 | 40 |
| 8 | 1.0 | 0.6 | 2.0 | LT155/208H4-40 | 3.7 | 40 | 10 | 15 | 40 |
| 17 | 1.5 | 1.0 | 2.7 | LT220/251H4-40 | 20.0 | 40 | 14 | 21 | 100 |
| 22 | 1.5 | 0.9 | 1.8 | LT300/252-4-40 | 31.0 | 40 | 2 | 22 | 200 |
| 29 | 2.0 | 1.2 | 1.4 | LT420/283-4-42 | 57.0 | 42 | 7 | 20 | 240 |
| 33 | 2.5 | 1.6 | 1.0 | LT530/286-4-42 | 90.0 | 42 | 2 | 20 | 245 |
| 40 | 1.5 | 0.8 | 1.2 | LTAII530/625-4-42 | 145.0 | 42 | 4 | 24 | 720 |

| 5 x 4 mm ² , Ø= 14.5mm, 0.32 kg/m, Tensile Force of Cable max. 2000 N | | | | | | | | | |
|--|-------|---------|-----|-------------------|-------------|----|--------|-------|--------|
| l (m) | h (m) | f1* (m) | NL | Type Series | Weight (kg) | A | nv.(U) | n.(U) | TF.(N) |
| 15 | 2.0 | 0.9 | 2.7 | LT220/251-5-40 | 16.0 | 40 | 2 | 18 | 100 |
| 19 | 1.5 | 1.0 | 1.8 | LT300/272-5-40 | 28.0 | 40 | 2 | 19 | 165 |
| 25 | 1.5 | 1.0 | 1.3 | LT420/283-5-42 | 57.0 | 42 | 8 | 18 | 240 |
| 34 | 1.5 | 1.7 | 1.1 | LT530/286-5-42 | 110.0 | 42 | 7 | 20 | 267 |
| 40 | 1.5 | 1.1 | 1.3 | LTAII530/625-5-42 | 132.0 | 42 | 4 | 23 | 600 |

| 4 x 6 mm ² , Ø= 14.8 mm, 0.37 kg/m, Tensile Force of Cable max. 2000 N | | | | | | | | | |
|---|-------|---------|-----|-------------------|-------------|----|--------|-------|--------|
| l (m) | h (m) | f1* (m) | NL | Type Series | Weight (kg) | A | nv.(U) | n.(U) | TF.(N) |
| 15 | 1.5 | 1.0 | 2.7 | LT220/151-4-60 | 16.0 | 60 | 2 | 18 | 100 |
| 19 | 1.5 | 1.0 | 1.8 | LT300/172-4-60 | 28.0 | 60 | 2 | 19 | 165 |
| 25 | 1.5 | 1.2 | 1.3 | LT420/283-4-60 | 57.0 | 60 | 8 | 18 | 240 |
| 30 | 1.5 | 1.6 | 1.0 | LT530/285-4-60 | 110.0 | 60 | 9 | 18 | 267 |
| 36 | 1.5 | 1.0 | 1.2 | LTAII530/525-4-60 | 132.0 | 60 | 6 | 21 | 600 |
| 41 | 1.5 | 1.4 | 1.3 | LTAII530/625-4-60 | 145.0 | 60 | 3 | 24 | 725 |

| 5 x 6 mm ² , Ø= 16.1mm, 0.43 kg/m, Tensile Force of Cable max. 2500 N | | | | | | | | | |
|--|-------|---------|-----|-------------------|-------------|----|--------|-------|--------|
| l (m) | h (m) | f1* (m) | NL | Type Series | Weight (kg) | A | nv.(U) | n.(U) | TF.(N) |
| 15 | 1.5 | 0.6 | 2.9 | LT220/251-5-60 | 19.1 | 60 | 2 | 18 | 200 |
| 20 | 1.5 | 1.0 | 1.9 | LT300/252-5-60 | 28.0 | 60 | 5 | 19 | 210 |
| 25 | 1.5 | 1.4 | 1.4 | LT420/283-5-60 | 57.0 | 60 | 8 | 27 | 240 |
| 34 | 1.5 | 1.4 | 1.2 | LT530/286-5-60 | 110.0 | 60 | 2 | 20 | 490 |
| 40 | 2.0 | 1.5 | 1.4 | LTAII530/525-5-60 | 133.0 | 60 | 4 | 23 | 600 |

| 4 x 10 mm ² , Ø= 18.8 mm, 0.61 kg/m, Tensile Force of Cable max. 2000 N | | | | | | | | | |
|--|-------|---------|-----|-------------------|-------------|----|--------|-------|--------|
| l (m) | h (m) | f1* (m) | NL | Type Series | Weight (kg) | A | nv.(U) | n.(U) | TF.(N) |
| 20 | 1.5 | 1.0 | 2.2 | LT300/272-4-60 | 28.0 | 60 | 2 | 19 | 330 |
| 23 | 1.5 | 1.7 | 1.6 | LT420/283-4-60 | 55.0 | 60 | 10 | 17 | 240 |
| 30 | 1.5 | 1.4 | 1.3 | LT530/286-4-60 | 131.0 | 60 | 4 | 18 | 490 |
| 35 | 2.0 | 1.6 | 1.4 | LTAII530/525-4-60 | 133.0 | 60 | 7 | 20 | 600 |
| 39 | 2.0 | 1.6 | 1.5 | LTAII530/625-4-60 | 145.0 | 60 | 5 | 22 | 725 |

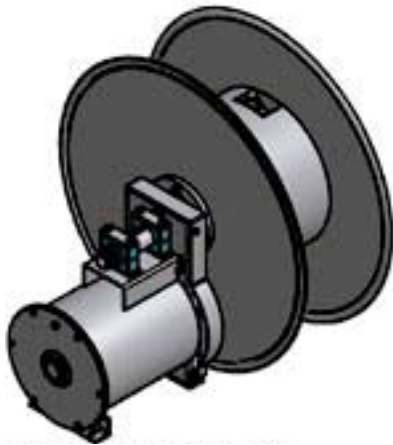

Type Series LTAI and LTAII



Spring Cable reeling Drums, cylindrical, horizontal freely suspended, v= 60 m/min Type Series LT, LTAI, LTAII



Type Series LT

| 4 x 16 mm ² , Ø= 23.4 mm, 0.92 kg/m, Tensile Force of Cable max. 2500 N | | | | | | | | | | |
|--|-------|---------|-----|--------------------|-------------|-----|--------|-------|--------|--|
| l (m) | h (m) | f1* (m) | NL | Type Series | Weight (kg) | A | nv.(U) | n.(U) | TF.(N) | |
| 20 | 1.5 | 1.0 | 1.1 | LT530/286-4-125 | 131.0 | 125 | 10 | 12 | 490 | |
| 25 | 1.5 | 1.2 | 1.4 | LTAII530/525-4-125 | 133.0 | 125 | 12 | 15 | 600 | |
| 30 | 2.0 | 1.5 | 1.5 | LTAII530/625-4-125 | 145.0 | 125 | 10 | 17 | 725 | |

| 4 x 25 mm ² , Ø= 27.1mm, 1.27 kg/m, Tensile Force of Cable max. 2500 N | | | | | | | | | | |
|---|-------|---------|-----|--------------------|-------------|-----|--------|-------|--------|--|
| l (m) | h (m) | f1* (m) | NL | Type Series | Weight (kg) | A | nv.(U) | n.(U) | TF.(N) | |
| 18 | 1.5 | 1.0 | 1.1 | LT530/286-4-150 | 132.0 | 150 | 12 | 10 | 490 | |
| 22 | 2.0 | 1.3 | 1.4 | LTAII530/525-4-150 | 135.0 | 150 | 14 | 13 | 600 | |
| 27 | 2.0 | 1.6 | 1.6 | LTAII530/625-4-150 | 148.0 | 150 | 12 | 15 | 725 | |

| 4 x 35 mm ² , Ø= 29.7mm, 1.72 kg/m, Tensile Force of Cable max. 2500 N | | | | | | | | | | |
|---|-------|---------|-----|--------------------|-------------|-----|--------|-------|--------|--|
| l (m) | h (m) | f1* (m) | NL | Type Series | Weight (kg) | A | nv.(U) | n.(U) | TF.(N) | |
| 18 | 2.0 | 1.2 | 1.3 | LTAII530/525-4-150 | 135.0 | 150 | 17 | 10 | 600 | |
| 20 | 2.0 | 1.2 | 1.4 | LTAII530/625-4-150 | 148.0 | 150 | 16 | 11 | 725 | |

| 4 x 50 mm ² , Ø= 35.1 mm, 2.63 kg/m, Tensile Force of Cable max. 3000 N | | | | | | | | | | |
|--|-------|---------|-----|--------------------|-------------|-----|--------|-------|--------|--|
| l (m) | h (m) | f1* (m) | NL | Type Series | Weight (kg) | A | nv.(U) | n.(U) | TF.(N) | |
| 17 | 2.0 | 1.4 | 1.4 | LTAII530/625-4-220 | 148.0 | 220 | 18 | 9 | 725 | |



Type Series LTAI and LTAII



Spring Cable reeling Drums, cylindrical, vertically downwards, v= 60 m/min Type Series LT, LTAI, LTAII



Type Series LT

| 4 x 1.5 mm ² , Ø 11.1 mm, 0.16 kg/m, Tensile Force of Cable max. 1200 N | | | | | | | |
|--|-----|----------------|-------------|----|--------|-------|--------|
| Vertical (m) | NL | Type Series | Weight (kg) | A | nv.(U) | n.(U) | TF.(N) |
| 7 | 2.0 | LT155/108-4-26 | 3.1 | 26 | 2 | 13 | 40 |
| 9 | 2.0 | LT155/208H4-26 | 3.7 | 26 | 4 | 16 | 40 |
| 12 | 2.0 | LT180/131-4-26 | 9.0 | 26 | 2 | 19 | 60 |
| 25 | 4.0 | LT220/251H4-26 | 19.0 | 26 | 6 | 31 | 100 |
| 35 | 4.0 | LT222/351H4-26 | 23.0 | 26 | 9 | 43 | 100 |
| 50 | 2.0 | LT301/372H4-26 | 58.0 | 26 | 9 | 51 | 165 |
| 64 | 1.0 | LT530/286H4-36 | 115.0 | 36 | 4 | 38 | 250 |

| 5 x 1.5 mm ² , Ø 11.8 mm, 0.18 kg/m, Tensile Force of Cable max. 1500 N | | | | | | | |
|--|-----|----------------|-------------|----|--------|-------|--------|
| Vertical (m) | NL | Type Series | Weight (kg) | A | nv.(U) | n.(U) | TF.(N) |
| 7 | 3.0 | LT155/108-5-26 | 3.1 | 26 | 2 | 13 | 40 |
| 8 | 3.0 | LT155/208H5-26 | 3.7 | 26 | 6 | 16 | 40 |
| 10 | 2.0 | LT180/131-5-26 | 8.0 | 26 | 3 | 18 | 60 |
| 11 | 3.0 | LT220/151-5-26 | 17.0 | 26 | 3 | 16 | 100 |
| 25 | 4.0 | LT220/251H5-26 | 19.0 | 26 | 6 | 32 | 100 |
| 33 | 2.0 | LT300/272H5-26 | 32.0 | 26 | 6 | 34 | 165 |
| 50 | 3.0 | LT301/372H5-26 | 38.0 | 26 | 9 | 51 | 165 |
| 64 | 2.0 | LT530/286H5-36 | 115.0 | 36 | 6 | 38 | 260 |

| 7 x 1.5 mm ² , Ø 13.3 mm, 0.23 kg/m, Tensile Force of Cable max. 2000 N | | | | | | | |
|--|-----|----------------|-------------|----|--------|-------|--------|
| Vertical (m) | NL | Type Series | Weight (kg) | A | nv.(U) | n.(U) | TF.(N) |
| 7 | 2.0 | LT155/108-7-26 | 3.1 | 26 | 2 | 13 | 40 |
| 10 | 2.0 | LT180/131-7-26 | 10.0 | 26 | 3 | 15 | 60 |
| 11 | 2.0 | LT220/151-7-26 | 18.0 | 26 | 3 | 16 | 100 |
| 19 | 4.0 | LT220/251H7-26 | 20.0 | 26 | 6 | 25 | 100 |
| 24 | 5.0 | LT222/351H7-26 | 25.0 | 26 | 9 | 48 | 100 |
| 34 | 3.0 | LT300/272H7-26 | 34.0 | 26 | 6 | 34 | 165 |
| 41 | 3.0 | LT301/372H7-26 | 40.0 | 26 | 9 | 51 | 165 |
| 49 | 3.0 | LT420/284H7-36 | 59.0 | 36 | 4 | 36 | 240 |
| 63 | 2.0 | LT530/286H7-36 | 115.0 | 36 | 4 | 38 | 260 |

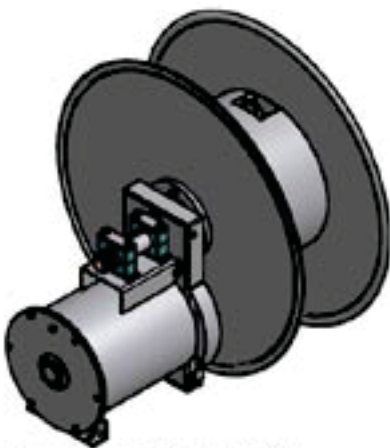

Type Series LTAI and LTAII

| 12 x 1.5 mm ² , Ø 16.9 mm, 0.36 kg/m, Tensile Force of Cable max. 2500 N | | | | | | | |
|---|-----|--------------------|-------------|----|--------|-------|--------|
| Vertical (m) | NL | Type Series | Weight (kg) | A | nv.(U) | n.(U) | TF.(N) |
| 7 | 2.0 | LT180/131-12-26 | 10.0 | 26 | 10 | 12 | 60 |
| 12 | 3.0 | LT220/151-12-26 | 19.0 | 26 | 4 | 15 | 100 |
| 15 | 3.0 | LT222/351H12-26 | 25.0 | 26 | 28 | 20 | 100 |
| 22 | 3.0 | LT300/152-12-36 | 30.0 | 36 | 3 | 22 | 100 |
| 26 | 3.0 | LT300/272H12-36 | 36.0 | 36 | 6 | 34 | 165 |
| 32 | 2.0 | LT420/283-12-36 | 58.0 | 36 | 3 | 24 | 240 |
| 40 | 3.0 | LT420/253-12-36 | 60.0 | 36 | 3 | 29 | 260 |
| 50 | 1.8 | LTAII530/525-12-36 | 128.0 | 36 | 4 | 29 | 400 |

| 18 x 1.5 mm ² , Ø 17.9 mm, 0.47 kg/m, Tensile Force of Cable max. 2500 N | | | | | | | |
|---|-----|--------------------|-------------|----|--------|-------|--------|
| Vertical (m) | NL | Type Series | Weight (kg) | A | nv.(U) | n.(U) | TF.(N) |
| 7 | 2.0 | LT220/151-18-36 | 23.0 | 36 | 3 | 10 | 100 |
| 12 | 2.7 | LT221/251-18-36 | 25.0 | 36 | 3 | 16 | 200 |
| 22 | 3.0 | LT300/252-18-36 | 30.0 | 36 | 3 | 22.5 | 200 |
| 28 | 2.0 | LT420/283-18-36 | 58.0 | 36 | 3 | 24 | 240 |
| 31 | 3.0 | LT420/253-18-36 | 61.0 | 36 | 3 | 29 | 255 |
| 34 | 2.0 | LT530/285-18-36 | 126.0 | 36 | 3 | 23 | 280 |
| 48 | 2.0 | LTAII530/525-18-36 | 150.0 | 36 | 6 | 27 | 500 |



Spring Cable reeling Drums, cylindrical, vertically downwards, v= 60 m/min Type Series LT, LTAI, LTAII



Type Series LT

| 24 x 1.5 mm ² , Ø 22.6 mm, 0.59 kg/m, Tensile Force of Cable max. 2500 N | | | | | | | |
|---|-----|--------------------|-------------|----|--------|-------|--------|
| Vertical (m) | NL | Type Series | Weight (kg) | A | nv.(U) | n.(U) | TF.(N) |
| 9 | 2.0 | LT300/152-24-36 | 28.0 | 36 | 8 | 10 | 100 |
| 14 | 1.9 | LT300/172-24-36 | 39.0 | 36 | 5 | 15 | 165 |
| 23 | 2.0 | LT420/283-24-36 | 63.0 | 36 | 8 | 18 | 240 |
| 24 | 2.0 | LT420/253-24-36 | 65.0 | 36 | 12 | 19 | 260 |
| 25 | 2.0 | LT420/284-24-36 | 67.0 | 36 | 3 | 18 | 465 |
| 32 | 2.0 | LT530/286-24-36 | 118.0 | 36 | 3 | 19 | 490 |
| 36 | 1.7 | LTAI530/425-24-36 | 128.0 | 36 | 5 | 20 | 480 |
| 45 | 2.1 | LTAII530/625-24-36 | 155.0 | 36 | 8 | 25 | 600 |

| 30 x 1.5 mm ² , Ø 24.2 mm, 0.71 kg/m, Tensile Force of Cable max. 2500 N | | | | | | | |
|---|-----|--------------------|-------------|----|--------|-------|--------|
| Vertical (m) | NL | Type Series | Weight (kg) | A | nv.(U) | n.(U) | TF.(N) |
| 8 | 2.0 | LT300/152-30-36 | 28.0 | 36 | 10 | 10 | 100 |
| 16 | 2.0 | LT300/252-30-36 | 31.0 | 36 | 12 | 13 | 210 |
| 18 | 3.0 | LT300/272-30-36 | 33.0 | 36 | 3 | 17 | 330 |
| 19 | 2.0 | LT420/283-30-36 | 63.0 | 36 | 8 | 15 | 240 |
| 20 | 2.0 | LT420/253-30-36 | 65.0 | 36 | 9 | 16 | 260 |
| 22 | 2.0 | LT420/284-30-36 | 66.0 | 36 | 3 | 17 | 470 |
| 25 | 3.0 | LT421/284-30-36 | 69.0 | 36 | 3 | 18 | 470 |
| 32 | 1.5 | LT530/286-30-36 | 118.0 | 36 | 3 | 19 | 500 |
| 38 | 1.9 | LTAII530/625-30-36 | 155.0 | 36 | 6 | 21 | 600 |

| 4 x 2.5 mm ² , Ø 12.3 mm, 0.21 kg/m, Tensile Force of Cable max. 1300 N | | | | | | | |
|--|-----|----------------|-------------|----|--------|-------|--------|
| Vertical (m) | NL | Type Series | Weight (kg) | A | nv.(U) | n.(U) | TF.(N) |
| 7 | 2.0 | LT155/108-4-26 | 3.1 | 26 | 2 | 13 | 40 |
| 10 | 2.0 | LT180/131-4-26 | 10.5 | 26 | 3 | 18 | 60 |
| 11 | 2.0 | LT220/151-4-26 | 18.0 | 25 | 3 | 16 | 100 |
| 25 | 4.0 | LT220/251H4-26 | 19.5 | 26 | 6 | 32 | 100 |
| 27 | 4.0 | LT222/351H4-26 | 22.0 | 26 | 9 | 48 | 100 |
| 34 | 4.0 | LT300/272H4-26 | 52.0 | 26 | 6 | 28 | 165 |
| 45 | 3.0 | LT301/372H4-26 | 55.0 | 26 | 9 | 51 | 165 |
| 48 | 2.0 | LT420/284H4-36 | 56.0 | 36 | 6 | 36 | 235 |
| 64 | 2.0 | LT530/286H4-36 | 114.0 | 36 | 6 | 38 | 250 |

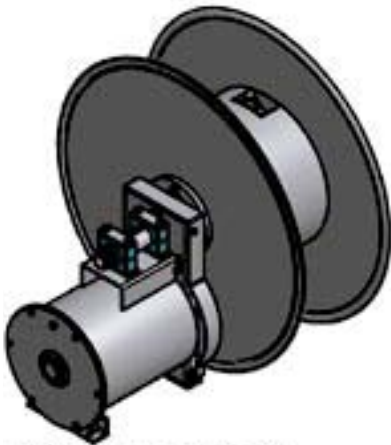

Type Series LTAI and LTAII

| 5 x 2.5 mm ² , Ø 13.0 mm, 0.24 kg/m, Tensile Force of Cable max. 1800 N | | | | | | | |
|--|-----|----------------|-------------|----|--------|-------|--------|
| Vertical (m) | NL | Type Series | Weight (kg) | A | nv.(U) | n.(U) | TF.(N) |
| 7 | 2.0 | LT155/108-5-26 | 3.1 | 26 | 2 | 13 | 40 |
| 10 | 2.0 | LT180/131-5-26 | 11.5 | 26 | 3 | 18 | 60 |
| 11 | 2.0 | LT220/151-5-26 | 16.0 | 26 | 3 | 16 | 100 |
| 23 | 3.0 | LT220/251H5-26 | 19.5 | 26 | 6 | 32 | 100 |
| 34 | 3.0 | LT300/272H5-26 | 52.0 | 26 | 6 | 34 | 165 |
| 39 | 3.0 | LT301/372H5-26 | 58.0 | 26 | 9 | 51 | 165 |
| 49 | 3.0 | LT420/284H5-36 | 61.0 | 36 | 6 | 36 | 240 |
| 61 | 2.0 | LT530/286H5-36 | 112.0 | 36 | 6 | 38 | 250 |



Spring Cable reeling Drums, cylindrical, vertically downwards, v= 60 m/min Type Series LT, LTAI, LTAII



Type Series LT

| 7 x 2.5 mm ² , Ø 14.0 mm, 0.31 kg/m, Tensile Force of Cable max. 2500 N | | | | | | | |
|--|-----|-------------------|-------------|----|--------|-------|--------|
| Vertical (m) | NL | Type Series | Weight (kg) | A | nv.(U) | n.(U) | TF.(N) |
| 5 | 2.0 | LT155/108-7-26 | 4.0 | 26 | 4 | 10 | 40 |
| 9 | 2.0 | LT180/131-7-26 | 10.0 | 26 | 4 | 17 | 60 |
| 12 | 3.0 | LT220/151-7-26 | 18.0 | 26 | 3 | 16 | 100 |
| 17 | 5.0 | LT220/251H7-26 | 20.0 | 26 | 8 | 31 | 100 |
| 18 | 4.0 | LT222/351H7-26 | 25.0 | 26 | 9 | 32 | 100 |
| 21 | 2.0 | LT300/252-7-26 | 31.0 | 26 | 3 | 22 | 210 |
| 32 | 2.0 | LT420/283-7-36 | 57.0 | 36 | 3 | 24 | 240 |
| 39 | 2.0 | LT420/253-7-36 | 59.0 | 36 | 3 | 29 | 260 |
| 43 | 2.0 | LT420/284H7-36 | 62.0 | 36 | 6 | 36 | 240 |
| 47 | 2.0 | LT530/286H7-36 | 115.0 | 36 | 6 | 38 | 250 |
| 50 | 1.3 | LTAII530/525-7-36 | 130.5 | 36 | 4 | 29 | 400 |

| 12 x 2.5 mm ² , Ø 20.2 mm, 0.48 kg/m, Tensile Force of Cable max. 2500 N | | | | | | | |
|---|-----|--------------------|-------------|----|--------|-------|--------|
| Vertical (m) | NL | Type Series | Weight (kg) | A | nv.(U) | n.(U) | TF.(N) |
| 11 | 2.0 | LT300/152-12-36 | 28.0 | 36 | 14 | 11 | 100 |
| 23 | 3.0 | LT300/252-12-36 | 30.0 | 36 | 3 | 22 | 210 |
| 28 | 2.0 | LT420/283-12-36 | 58.0 | 36 | 7 | 20 | 240 |
| 30 | 3.0 | LT420/253-12-36 | 69.0 | 36 | 10 | 22 | 260 |
| 33 | 2.0 | LT530/285-12-36 | 110.0 | 36 | 7 | 19 | 280 |
| 40 | 1.8 | LTAI530/425-12-36 | 128.0 | 36 | 4 | 23 | 480 |
| 50 | 2.1 | LTAII530/625-12-36 | 145.0 | 36 | 5 | 28 | 600 |

| 18 x 2.5 mm ² , Ø 20.6 mm, 0.68 kg/m, Tensile Force of Cable max. 2500 N | | | | | | | |
|---|-----|--------------------|-------------|----|--------|-------|--------|
| Vertical (m) | NL | Type Series | Weight (kg) | A | nv.(U) | n.(U) | TF.(N) |
| 8 | 2.0 | LT300/152-18-36 | 29.0 | 36 | 15 | 10 | 100 |
| 16 | 3.0 | LT300/252-18-36 | 32.0 | 36 | 10 | 15 | 200 |
| 17 | 3.0 | LT300/272-18-36 | 34.0 | 36 | 3 | 17 | 330 |
| 20 | 2.0 | LT420/283-18-36 | 60.0 | 36 | 13 | 14 | 240 |
| 21 | 2.0 | LT420/253-18-36 | 62.0 | 36 | 14 | 16 | 260 |
| 24 | 2.0 | LT420/284-18-36 | 63.0 | 36 | 3 | 18 | 470 |
| 32 | 2.0 | LT530/286-18-36 | 110.0 | 36 | 3 | 19 | 500 |
| 35 | 1.5 | LTAII530/525-18-36 | 143.0 | 36 | 7 | 20 | 600 |
| 43 | 1.9 | LTAII530/625-18-36 | 145.0 | 36 | 3 | 24 | 725 |

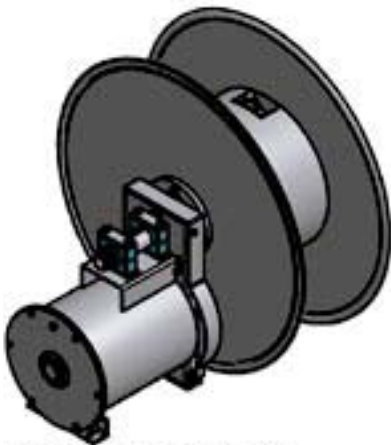

Type Series LTAI and LTAII

| 24 x 2.5 mm ² , Ø 25.5 mm, 0.82 kg/m, Tensile Force of Cable max. 2500 N | | | | | | | |
|---|-----|--------------------|-------------|----|--------|-------|--------|
| Vertical (m) | NL | Type Series | Weight (kg) | A | nv.(U) | n.(U) | TF.(N) |
| 12 | 2.0 | LT300/252-24-36 | 31.0 | 36 | 10 | 12 | 200 |
| 16 | 2.0 | LT420/283-24-36 | 57.0 | 36 | 16 | 11 | 240 |
| 17 | 2.0 | LT420/253-24-36 | 59.0 | 36 | 16 | 17 | 260 |
| 22 | 2.0 | LT420/284-24-36 | 61.0 | 36 | 5 | 16 | 470 |
| 25 | 3.0 | LT421/284-24-36 | 64.0 | 36 | 3 | 18 | 470 |
| 33 | 2.0 | LT530/286-24-36 | 110.0 | 36 | 3 | 19 | 490 |
| 28 | 1.6 | LTAII530/525-24-36 | 143.0 | 36 | 11 | 16 | 600 |
| 38 | 2.0 | LTAII530/625-24-36 | 145.0 | 36 | 6 | 21 | 725 |



Spring Cable reeling Drums, cylindrical, vertically downwards, v= 60 m/min Type Series LT, LTAI, LTAII



Type Series LT

| 30 x 2.5 mm ² , Ø 28.7mm, 0.97 kg/m, Tensile Force of Cable max. 2500 N | | | | | | | |
|--|-----|--------------------|-------------|----|--------|-------|--------|
| Vertical (m) | NL | Type Series | Weight (kg) | A | nv.(U) | n.(U) | TF.(N) |
| 7 | 1.0 | LT420/183-30-36 | 57.0 | 36 | 19 | 6 | 120 |
| 14 | 2.0 | LT420/283-30-36 | 60.0 | 36 | 17 | 10 | 240 |
| 15 | 2.0 | LT420/253-30-36 | 62.0 | 36 | 20 | 11 | 260 |
| 20 | 2.0 | LT420/284-30-36 | 65.0 | 36 | 7 | 14 | 470 |
| 26 | 3.0 | LT421/284-30-36 | 67.0 | 36 | 3 | 18 | 470 |
| 30 | 2.0 | LT530/286-30-36 | 110.0 | 36 | 5 | 17 | 500 |
| 32 | 2.0 | LTAII530/625-30-36 | 145.0 | 36 | 9 | 18 | 725 |

| 4 x 4 mm ² , Ø 13.4 mm, 0.28 kg/m, Tensile Force of Cable max. 1800 N | | | | | | | |
|--|-----|----------------|-------------|----|--------|-------|--------|
| Vertical (m) | NL | Type Series | Weight (kg) | A | nv.(U) | n.(U) | TF.(N) |
| 5 | 2.0 | LT155/108-4-40 | 3.5 | 40 | 3 | 11 | 40 |
| 10 | 3.0 | LT180/131-4-40 | 10.5 | 40 | 4 | 17 | 60 |
| 12 | 3.0 | LT220/151-4-40 | 18.0 | 40 | 3 | 16 | 100 |
| 17 | 2.0 | LT220/251H4-40 | 20.0 | 40 | 12 | 22 | 100 |
| 20 | 3.0 | LT222/351H4-40 | 24.0 | 40 | 22 | 26 | 100 |
| 22 | 1.9 | LT300/252-4-40 | 31.0 | 40 | 2 | 23 | 210 |
| 34 | 3.0 | LT300/272H4-40 | 37.0 | 40 | 6 | 34 | 180 |
| 39 | 2.0 | LT420/253-4-42 | 60.0 | 42 | 3 | 29 | 260 |
| 48 | 3.0 | LT420/284H4-42 | 64.0 | 42 | 6 | 36 | 470 |
| 52 | 2.0 | LT530/286H4-42 | 104.0 | 42 | 6 | 38 | 250 |

| 5 x 4 mm ² , Ø 14.5 mm, 0.32 kg/m, Tensile Force of Cable max. 2000 N | | | | | | | |
|--|-----|----------------|-------------|----|--------|-------|--------|
| Vertical (m) | NL | Type Series | Weight (kg) | A | nv.(U) | n.(U) | TF.(N) |
| 5 | 2.0 | LT155/108-5-40 | 4.0 | 40 | 3 | 11 | 40 |
| 8 | 2.0 | LT180/131-5-40 | 11.0 | 40 | 7 | 14 | 60 |
| 12 | 3.0 | LT220/151-5-40 | 18.0 | 40 | 3 | 16 | 100 |
| 17 | 3.0 | LT220/251H5-40 | 20.0 | 40 | 12 | 22 | 100 |
| 21 | 2.0 | LT300/252-5-40 | 28.0 | 40 | 3 | 22 | 200 |
| 29 | 3.0 | LT300/272H5-40 | 31.0 | 40 | 8 | 29 | 165 |
| 32 | 2.0 | LT420/283-5-42 | 58.0 | 42 | 3 | 24 | 240 |
| 39 | 2.0 | LT420/253-5-42 | 60.0 | 42 | 3 | 29 | 260 |
| 42 | 3.0 | LT420/284H5-42 | 63.0 | 42 | 6 | 36 | 240 |
| 45 | 2.0 | LT530/286H5-42 | 110.0 | 42 | 6 | 38 | 250 |

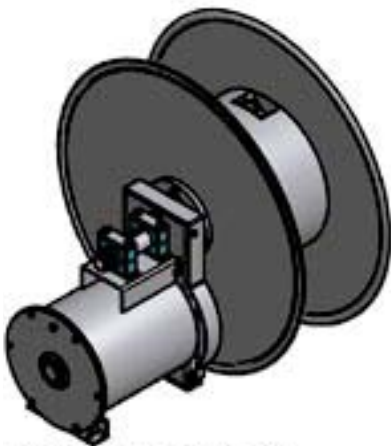

Type Series LTAI and LTAII

| 4 x 6 mm ² , Ø 14.8 mm, 0.37 kg/m, Tensile Force of Cable max. 2000 N | | | | | | | |
|--|-----|------------------|-------------|----|--------|-------|--------|
| Vertical (m) | NL | Type Series | Weight (kg) | A | nv.(U) | n.(U) | TF.(N) |
| 12 | 3.0 | LT220/151-4-60 | 19.0 | 60 | 3 | 16 | 100 |
| 15 | 3.0 | LT220/251H4-60 | 20.0 | 60 | 14 | 18 | 100 |
| 21 | 2.0 | LT300/252-4-60 | 31.0 | 60 | 3 | 22 | 200 |
| 25 | 3.0 | LT300/272-4-60 | 59.0 | 60 | 12 | 25 | 330 |
| 32 | 2.0 | LT420/283-4-60 | 56.0 | 60 | 3 | 24 | 240 |
| 39 | 2.0 | LT420/253-4-60 | 59.0 | 60 | 3 | 29 | 260 |
| 42 | 1.6 | LTAI530/425-4-60 | 130.5 | 60 | 3 | 24 | 400 |

| 5 x 6 mm ² , Ø 16.1 mm, 0.43 kg/m, Tensile Force of Cable max. 2500 N | | | | | | | |
|--|-----|------------------|-------------|----|--------|-------|--------|
| Vertical (m) | NL | Type Series | Weight (kg) | A | nv.(U) | n.(U) | TF.(N) |
| 9 | 2.0 | LT220/151-5-60 | 18.0 | 60 | 7 | 12 | 100 |
| 13 | 3.0 | LT220/251H5-60 | 22.0 | 60 | 16 | 18 | 100 |
| 22 | 3.0 | LT300/252-5-60 | 31.0 | 60 | 3 | 22 | 200 |
| 31 | 2.0 | LT420/283-5-60 | 57.0 | 60 | 3 | 24 | 240 |
| 34 | 2.0 | LT420/253-5-60 | 59.0 | 60 | 6 | 26 | 260 |
| 37 | 2.0 | LT530/285-5-60 | 112.0 | 60 | 3 | 23 | 280 |
| 42 | 1.4 | LTAI530/425-5-60 | 130.5 | 60 | 3 | 24 | 480 |



Spring Cable reeling Drums, cylindrical, vertically downwards, v= 60 m/min Type Series LT, LTAI, LTAII



Type Series LT

| 4 x 10 mm ² , Ø 18.8 mm, 0.61 kg/m, Tensile Force of Cable max. 2000 N | | | | | | | |
|---|-----|-------------------|-------------|----|--------|-------|--------|
| Vertical (m) | NL | Type Series | Weight (kg) | A | nv.(U) | n.(U) | TF.(N) |
| 7 | 2.0 | LT220/151-4-60 | 19.0 | 60 | 9 | 10 | 100 |
| 12 | 3.0 | LT222/351H4-60 | 31.0 | 60 | 4 | 15 | 100 |
| 18 | 2.0 | LT300/252-4-60 | 31.0 | 60 | 5 | 20 | 200 |
| 22 | 2.0 | LT420/283-4-60 | 56.0 | 60 | 11 | 16 | 240 |
| 24 | 2.0 | LT420/253-4-60 | 59.0 | 60 | 16 | 16 | 260 |
| 26 | 2.0 | LT530/285-4-60 | 108.0 | 60 | 11 | 15 | 280 |
| 32 | 2.0 | LT530/286-4-60 | 110.0 | 60 | 3 | 19 | 500 |
| 42 | 1.7 | LTAII530/525-4-60 | 135.0 | 60 | 3 | 24 | 600 |
| 44 | 2.1 | LTAII530/625-4-60 | 148.0 | 60 | 8 | 25 | 600 |

| 4 x 16 mm ² , Ø 23.4 mm, 0.92 kg/m, Tensile Force of Cable max. 2500 N | | | | | | | |
|---|-----|--------------------|-------------|-----|--------|-------|--------|
| Vertical (m) | NL | Type Series | Weight (kg) | A | nv.(U) | (n.U) | TF.(N) |
| 6 | 1.0 | LT300/152-4-125 | 29.0 | 125 | 17 | 7 | 100 |
| 12 | 2.0 | LT300/252-4-125 | 32.0 | 125 | 13 | 12 | 200 |
| 18 | 2.0 | LT300/272-4-125 | 36.0 | 125 | 3 | 17 | 330 |
| 25 | 2.0 | LT420/284-4-150 | 64.0 | 150 | 3 | 18 | 470 |
| 31 | 2.0 | LT530/286-4-150 | 115.0 | 150 | 4 | 18 | 500 |
| 35 | 2.1 | LTAII530/625-4-150 | 150.0 | 150 | 3 | 24 | 720 |

| 4 x 25 mm ² , Ø 27,1 mm, 1,27 kg/m, Tensile Force of Cable max. 2500 N | | | | | | | |
|---|-----|--------------------|-------------|-----|--------|-------|--------|
| Vertical (m) | NL | Type Series | Weight (kg) | A | nv.(U) | n.(U) | TF.(N) |
| 10 | 2.0 | LT420/283-4-150 | 62.0 | 150 | 19 | 8 | 240 |
| 20 | 2.0 | LT420/284-4-150 | 64.0 | 150 | 6 | 15 | 470 |
| 21 | 2.0 | LT421/284-4-150 | 67.0 | 150 | 4 | 17 | 470 |
| 23 | 2.0 | LT530/286-4-150 | 115.0 | 150 | 10 | 12 | 500 |
| 25 | 1.5 | LTAII530/625-4-150 | 150.0 | 150 | 13 | 14 | 720 |

| 4 x 35 mm ² , Ø 29.7 mm, 1.72 kg/m, Tensile Force of Cable max. 2500 N | | | | | | | |
|---|-----|--------------------|-------------|-----|--------|-------|--------|
| Vertical (m) | NL | Type Series | Weight (kg) | A | nv.(U) | n.(U) | TF.(N) |
| 8 | 1.0 | LT420/253-4-150 | 66.0 | 150 | 24 | 7 | 260 |
| 15 | 2.0 | LT420/284-4-150 | 68.0 | 150 | 10 | 11 | 470 |
| 17 | 2.0 | LT530/286-4-150 | 115.0 | 150 | 12 | 10 | 500 |
| 19 | 1.3 | LTAII530/625-4-150 | 150.0 | 150 | 17 | 10 | 720 |

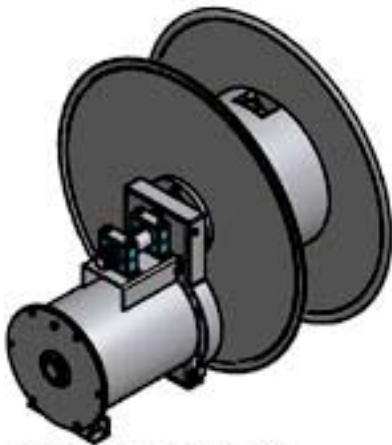

Type Series LTAI and LTAII



Dimension Sheets LT

| Type Series | Drawing No. | Ø d | Ø D | a | b | Ø e | Ø f | Ø f1 | Ø g | Ø h | Ø i | i1 | k |
|-------------|--------------|-----|-----|-----|-----|-----|-----|------|-----|-----|----------|----|----|
| LT155 | 01-95-00-0-3 | 155 | 260 | 101 | 110 | 35 | 155 | -- | 65 | 85 | 4 x Ø 9 | -- | 5 |
| LT180 | 01-95-00-0-3 | 180 | 300 | 109 | 130 | 35 | 180 | -- | 65 | 85 | 4 x Ø 9 | -- | 5 |
| LT220 | 01-95-00-0-3 | 220 | 400 | 114 | 120 | 35 | 220 | -- | 100 | 130 | 4 x Ø 13 | 6 | 12 |
| LT221 | 01-95-00-0-3 | 220 | 450 | 129 | 150 | 35 | 220 | -- | 100 | 130 | 4 x Ø 13 | 6 | 12 |
| LT222 | 01-95-00-0-3 | 220 | 450 | 139 | 170 | 35 | 220 | -- | 100 | 130 | 4 x Ø 13 | 6 | 12 |
| LT300 | 01-95-00-0-3 | 300 | 550 | 165 | 190 | 50 | 300 | -- | 100 | 135 | 4 x Ø 13 | 5 | 20 |
| LT301 | 01-95-00-0-3 | 300 | 550 | 213 | 285 | 50 | 300 | -- | 100 | 135 | 4 x Ø 13 | 5 | 20 |
| LT420 | 01-95-00-0-3 | 420 | 680 | 200 | 240 | 60 | 420 | -- | 135 | 178 | 4 x Ø 17 | 5 | 20 |
| LT421 | 01-95-00-0-3 | 420 | 770 | 200 | 240 | 60 | 420 | -- | 175 | 215 | 4 x Ø 17 | 5 | 20 |
| LT530 | 01-95-00-0-3 | 530 | 900 | 260 | 310 | 70 | 420 | -- | 185 | 250 | 4 x Ø 18 | 15 | 23 |

Cover dimension c in mm based on the number of poles

| Type Series | 3+Earth 26A | 3+Earth 36A | 3+Earth 40A | 3+Earth 42A | 3+Earth 60A | 3+Earth 125A | 3+Earth 150A | 3+Earth 220A | 4+Earth 26A | 4+Earth 36A | 4+Earth 40A | 4+Earth 42A | 4+Earth 60A |
|-------------|----------------|----------------|----------------|----------------|----------------|-----------------|-----------------|-----------------|----------------|----------------|----------------|----------------|----------------|
| LT155 | 60 | -- | 60 | -- | -- | -- | -- | -- | 60 | -- | 90 | -- | -- |
| LT180 | 90 | -- | 90 | -- | -- | -- | -- | -- | 90 | -- | 90 | -- | -- |
| LT220 | 50 | 100 | 50 | 100 | 100 | -- | -- | -- | 75 | 75 | 75 | 75 | 100 |
| LT221 | 50 | 75 | 50 | 75 | 75 | -- | -- | -- | 50 | 75 | 50 | 75 | 100 |
| LT222 | 50 | 35 | 50 | 35 | 35 | -- | -- | -- | 60 | 60 | 60 | -- | 85 |
| LT300 | 80 | 80 | 80 | 80 | 80 | 120 | -- | -- | 80 | 80 | 80 | 80 | 80 |
| LT301 | 80 | 80 | 80 | 80 | 80 | 80 | -- | -- | 80 | 80 | 80 | 80 | 80 |
| LT420 | -- | 85 | 85 | -- | 85 | -- | 85 | -- | -- | 85 | -- | 85 | 85 |
| LT421 | -- | 85 | -- | 85 | 85 | -- | 85 | -- | -- | 85 | -- | 85 | 85 |
| LT530 | -- | 85 | -- | 85 | 85 | -- | 85 | 85 | -- | 85 | -- | 85 | 85 |

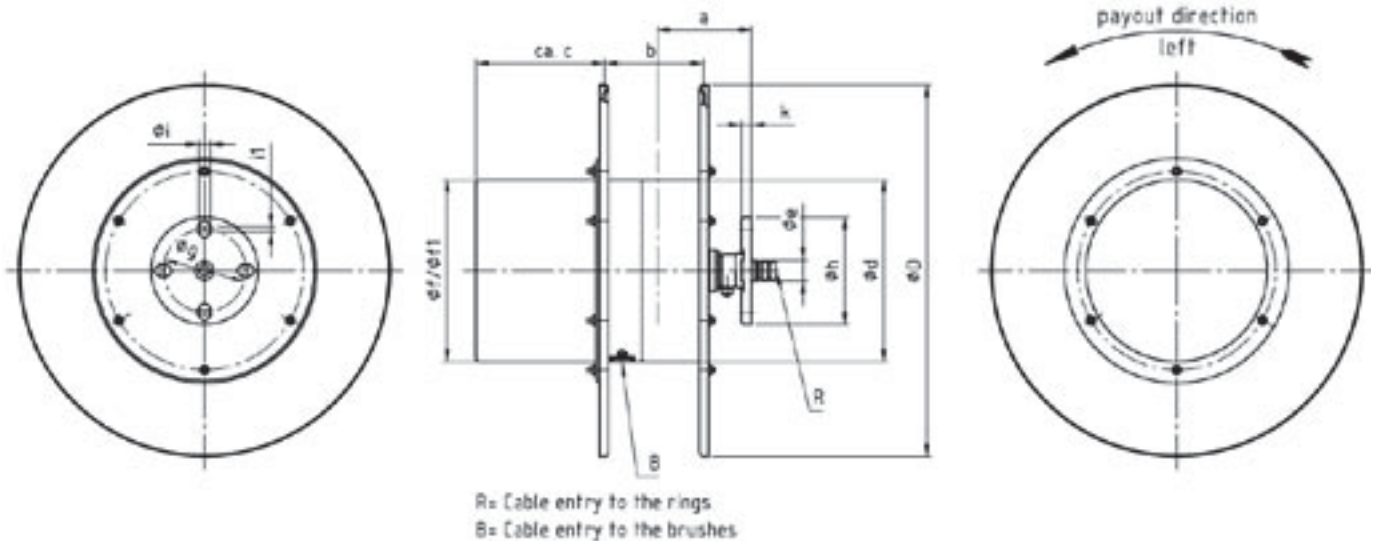



Dimension Sheets LTA

| Type Series | Drawing No. | Ø d | Ø D | a | b | e | Øf | Øf1 | g | h | c | k |
|-------------|--------------|-----|------|-----|-----|-----|-----|-----|-----|-----|-----|-----|
| LTAI 420 | 02-66-00-0-4 | 420 | 680 | 260 | 240 | 206 | 420 | 300 | 500 | 290 | 320 | 358 |
| LTAI 421 | 02-66-00-0-4 | 420 | 770 | 260 | 240 | 206 | 420 | 300 | 500 | 290 | 315 | 358 |
| LTAI 530 | 02-66-00-0-4 | 530 | 900 | 260 | 310 | 241 | 420 | 300 | 500 | 290 | 315 | 358 |
| LTAII 530 | 02-66-00-0-4 | 530 | 900 | 390 | 310 | 241 | 420 | 300 | 500 | 290 | 445 | 488 |
| LTAI 701 | 02-66-00-0-4 | 700 | 1200 | 260 | 350 | 255 | 300 | 300 | 500 | 290 | 315 | 358 |
| LTAII 701 | 02-66-00-0-4 | 700 | 1200 | 390 | 350 | 255 | 300 | 300 | 500 | 290 | 445 | 488 |

Cover dimension i in mm based on the number of poles.

| Type Series | 3+Earth 36A | 3+Earth 40A | 3+Earth 60A | 3+Earth 150A | 3+Earth 220A | 4+Earth 36A | 4+Earth 42A | 4+Earth 60A |
|-------------|----------------|----------------|----------------|-----------------|-----------------|----------------|----------------|----------------|
| LTAI 420 | -- | -- | -- | -- | 90 | -- | -- | -- |
| LTAI 421 | -- | -- | -- | -- | 90 | -- | -- | -- |
| LTAI 530 | -- | -- | -- | -- | -- | -- | -- | -- |
| LTAII 530 | -- | -- | -- | -- | -- | -- | -- | -- |
| LTAI 700 | -- | -- | -- | -- | -- | -- | -- | -- |
| LTAII 700 | -- | -- | -- | -- | -- | -- | -- | -- |
| LTAI 701 | -- | -- | -- | -- | -- | -- | -- | -- |
| LTAII 701 | -- | -- | -- | -- | -- | -- | -- | -- |

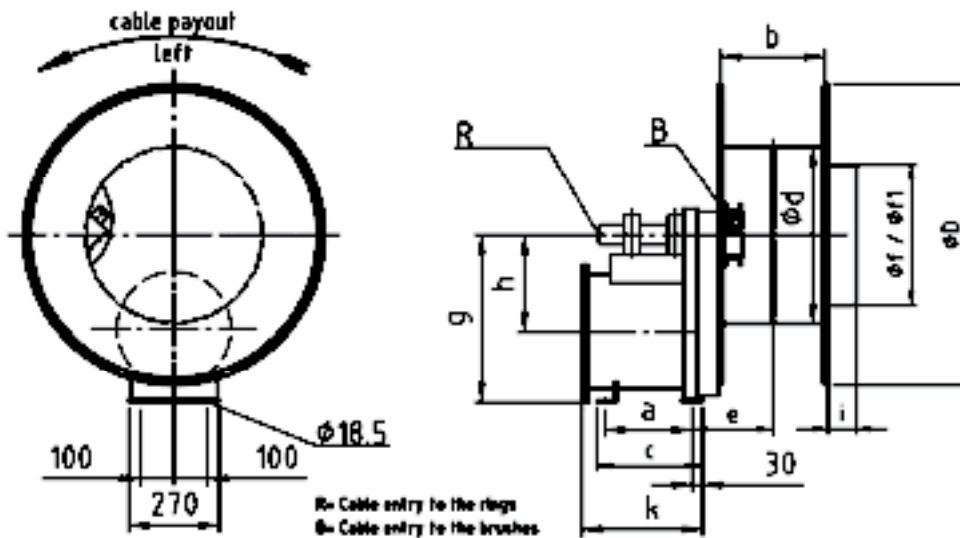



Dimension Sheets LT

| Type Series | Drawing No. | Ø d | Ø D | a | b | Ø e | Ø f | Ø f ₁ | Ø g | Ø h | Ø i | k |
|-------------|--------------|-----|-----|-----|-----|-----|-----|------------------|-----|-----|----------|----|
| LT155 | 01-95-00-0-3 | 155 | 260 | 101 | 110 | 35 | 155 | -- | 65 | 85 | 4 x Ø 09 | 5 |
| LT180 | 01-95-00-0-3 | 180 | 290 | 109 | 130 | 35 | 180 | -- | 65 | 85 | 4 x Ø 09 | 5 |
| LT220 | 01-95-00-0-3 | 220 | 400 | 114 | 120 | 35 | 220 | -- | 100 | 130 | 4 x Ø 14 | 12 |
| LT221 | 01-95-00-0-3 | 220 | 450 | 129 | 150 | 35 | 220 | -- | 100 | 130 | 4 x Ø 14 | 12 |
| LT222 | 01-95-00-0-3 | 220 | 450 | 139 | 170 | 35 | 220 | -- | 100 | 130 | 4 x Ø 14 | 12 |
| LT300 | 01-95-00-0-3 | 300 | 550 | 165 | 190 | 50 | 300 | -- | 100 | 135 | 4 x Ø 15 | 20 |
| LT301 | 01-95-00-0-3 | 300 | 550 | 213 | 285 | 50 | 300 | -- | 100 | 135 | 4 x Ø 16 | 20 |
| LT420 | 01-95-00-0-3 | 420 | 680 | 200 | 240 | 60 | 420 | 300 | 135 | 178 | 4 x Ø 18 | 20 |
| LT421 | 01-95-00-0-3 | 420 | 770 | 200 | 240 | 60 | 420 | 300 | 175 | 215 | 4 x Ø 18 | 20 |
| LT530 | 01-95-00-0-3 | 530 | 900 | 260 | 310 | 75 | 420 | 300 | 185 | 250 | 4 x Ø 18 | 23 |

Cover dimension c in mm based on the number of poles.

| Type Series | Drawing No. | 6+Earth 26 A | 6+Earth 36A | 11+Earth 26A | 11+Earth 36A | 17+Earth 36 A | 23+Earth 36 A | 29+Earth 36 A |
|-------------|--------------|-----------------|----------------|-----------------|-----------------|------------------|------------------|------------------|
| LT155 | 01-95-00-0-3 | 100 | -- | 150 | -- | -- | -- | -- |
| LT180 | 01-95-00-0-3 | 100 | -- | 150 | -- | -- | -- | -- |
| LT220 | 01-95-00-0-3 | 100 | 100 | 150 | 200 | 250 | 350 | -- |
| LT221 | 01-95-00-0-3 | 75 | 75 | 130 | 130 | 200 | 350 | -- |
| LT222 | 01-95-00-0-3 | 75 | 75 | 130 | 130 | 200 | 350 | 350 |
| LT300 | 01-95-00-0-3 | 80 | 80 | 150 | 150 | 200 | 320 | 400 |
| LT301 | 01-95-00-0-3 | 80 | 80 | 120 | 120 | 200 | 320 | 400 |
| LT420 | 01-95-00-0-3 | -- | 85 | -- | 155 | 235 ¹ | 355 ¹ | 435 ¹ |
| LT421 | 01-95-00-0-3 | -- | 85 | -- | 155 | 235 ¹ | 355 ¹ | 435 ¹ |
| LT530 | 01-95-00-0-3 | -- | 85 | -- | 85 | 155 | 355 ¹ | 355 ¹ |

¹ = 1 = see Ø f₁ of cover

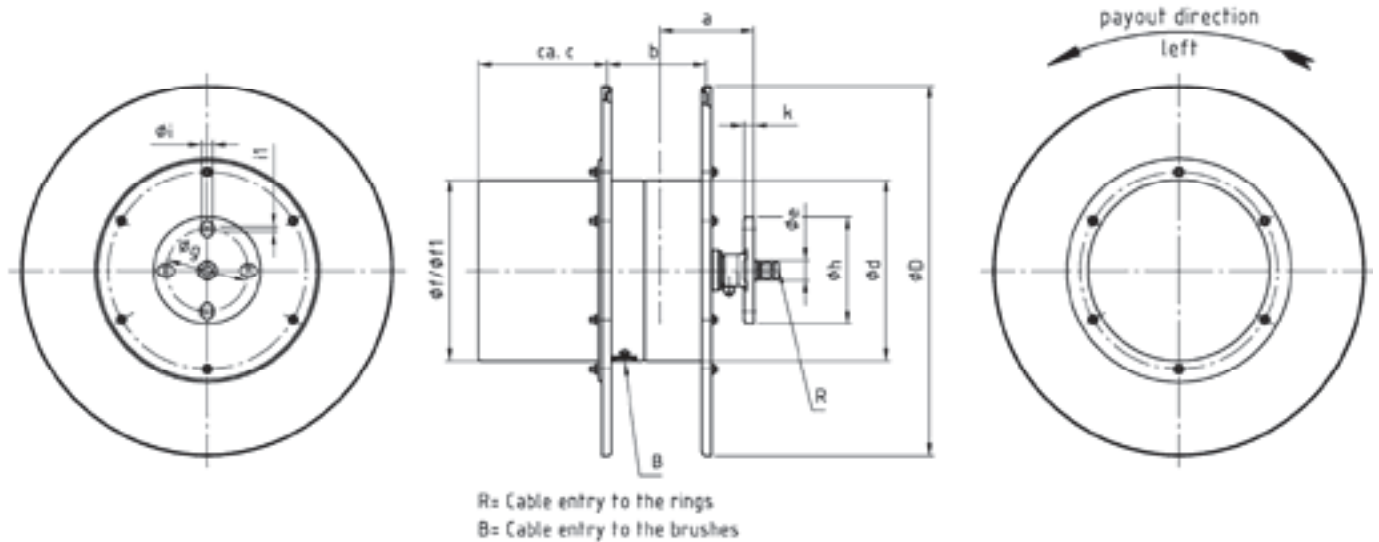



Dimension Sheets LTA

| Type Series | Drawing No. | Ø d | Ø D | a | b | ~ e | Ø f | Ø f ₁ | Ø g | Ø h | Ø i | k |
|-------------|--------------|-----|------|-----|-----|-----|-----|------------------|-----|-----|-----|-----|
| LTAI 421 | 02-66-00-0-4 | 420 | 770 | 260 | 240 | 206 | 420 | 300 | 500 | 290 | 315 | 358 |
| LTAI 530 | 02-66-00-0-5 | 530 | 900 | 260 | 310 | 241 | 420 | 300 | 500 | 290 | 315 | 358 |
| LTAII 530 | 02-66-00-0-6 | 530 | 900 | 390 | 310 | 241 | 420 | 300 | 500 | 290 | 445 | 488 |
| LTAII 700 | 02-66-00-0-9 | 700 | 1200 | 390 | 350 | 255 | 420 | 300 | 500 | 290 | 445 | 488 |

Cover dimension c in mm based on the number of poles.

| Type Series | Drawing No. | 6+Earth 36A | 11+Earth 36A | 17+Earth 36 A | 23+Earth 36 A | 29+Earth 36 A |
|-------------|--------------|----------------|-----------------|------------------|------------------|------------------|
| LTAI 421 | 02-66-00-0-4 | -- | 90 | 155 | 250 ¹ | 320 ¹ |
| LTAI 530 | 02-66-00-0-5 | -- | -- | 90 | 160 | 260 ¹ |
| LTAII 530 | 02-66-00-0-6 | -- | -- | 90 | 160 | 260 ¹ |
| LTAII 700 | 02-66-00-0-9 | -- | -- | 25 ¹ | 155 ¹ | 255 ¹ |

¹ = 1 = see Ø f₁ of cover

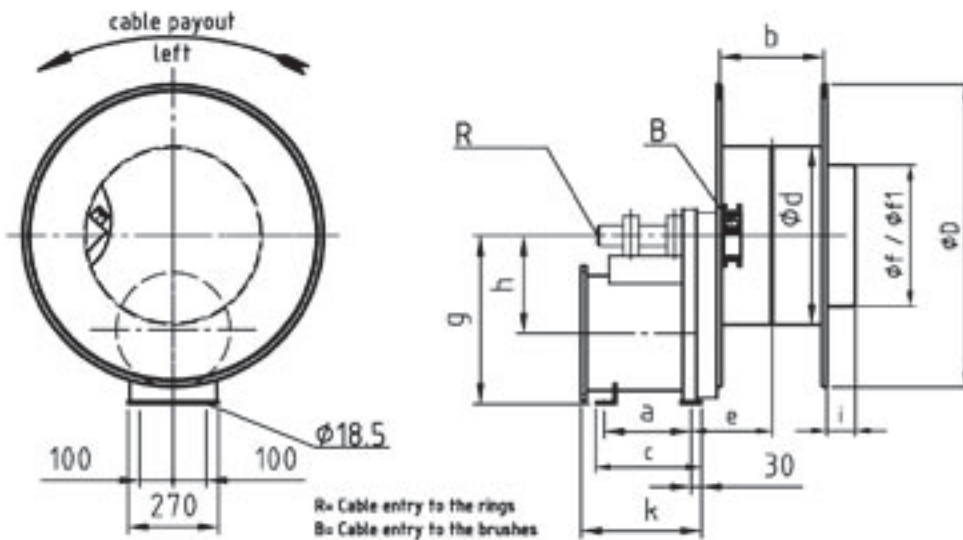



Spring Cable reeling Drums, spiral, horizontal, v= 60 m/min Type Series LTSP, LTAISP, LTAISP



Type Series LTSP

| 4 x 6 mm ² , Ø= 14.8 mm, 0.37 kg/m, Tensile Force of Cable max. 2000 N | | | | | | | |
|---|-------|---------------------|-------------|----|--------|-------|--------|
| l (m) | h (m) | Type Series | Weight (kg) | A | nv.(U) | n.(U) | TF.(N) |
| 10 | 1.0 | LTSP2/6/251-4-60 | 73.0 | 60 | 10 | 7 | 157 |
| 25 | 1.5 | LTSP3/9/252-4-60 | 100.0 | 60 | 9 | 14 | 180 |
| 33 | 1.5 | LTSP4/10/283-4-60 | 120.0 | 60 | 11 | 16 | 240 |
| 50 | 1.5 | LTAISP6/12/325-4-60 | 150.0 | 60 | 7 | 20 | 320 |
| 90 | 1.5 | LTAISP6/15/325-4-60 | 160.0 | 60 | 6 | 27 | 320 |
| 115 | 1.5 | LTAISP6/18/525-4-60 | 300.0 | 60 | 6 | 32 | 380 |
| 135 | 1.5 | LTAISP8/20/625-4-60 | 400.0 | 60 | 6 | 32 | 340 |

| 5 x 6 mm ² , Ø= 16.1 mm, 0.43 kg/m, Tensile Force of Cable max. 2500 N | | | | | | | |
|---|-------|---------------------|-------------|----|--------|-------|--------|
| l (m) | h (m) | Type Series | Weight (kg) | A | nv.(U) | n.(U) | TF.(N) |
| 25 | 1.5 | LTSP3/9/252-5-60 | 100.0 | 60 | 9 | 13 | 180 |
| 30 | 1.5 | LTSP4/10/283-5-60 | 120.0 | 60 | 13 | 14 | 240 |
| 45 | 1.5 | LTAISP6/12/325-5-60 | 150.0 | 60 | 11 | 16 | 210 |
| 90 | 1.5 | LTAISP6/15/525-5-60 | 160.0 | 60 | 4 | 29 | 265 |
| 120 | 1.5 | LTAISP6/18/525-5-60 | 300.0 | 60 | 5 | 33 | 380 |
| 130 | 1.5 | LTAISP8/20/625-5-60 | 400.0 | 60 | 7 | 31 | 340 |

| 4 x 10 mm ² , Ø= 18.8 mm, 0.61 kg/m, Tensile Force of Cable max. 2000 N | | | | | | | |
|--|-------|---------------------|-------------|----|--------|-------|--------|
| l (m) | h (m) | Type Series | Weight (kg) | A | nv.(U) | n.(U) | TF.(N) |
| 23 | 1.0 | LTSP3/9/272-4-60 | 100.0 | 60 | 9 | 12 | 285 |
| 30 | 1.5 | LTSP4/10/283-4-60 | 120.0 | 60 | 13 | 13 | 240 |
| 37 | 1.5 | LTAISP6/12/325-4-60 | 150.0 | 60 | 14 | 13 | 320 |
| 70 | 1.5 | LTAISP6/15/425-4-60 | 160.0 | 60 | 12 | 21 | 355 |
| 100 | 1.5 | LTAISP6/18/525-4-60 | 300.0 | 60 | 6 | 27 | 445 |
| 120 | 1.5 | LTAISP8/20/625-4-60 | 400.0 | 60 | 5 | 28 | 400 |



Type Series LTAISP and LTAISP

| 4 x 16 mm ² , Ø= 23.4 mm, 0.92 kg/m, Tensile Force of Cable max. 2500 N | | | | | | | |
|--|-------|-----------------------|-------------|-----|--------|-------|--------|
| l (m) | h (m) | Type Series | Weight (kg) | A | nv.(U) | n.(U) | TF.(N) |
| 20 | 1.5 | LTSP4/10/283-4-125 | 125.0 | 125 | 15 | 10 | 240 |
| 28 | 1.5 | LTAISP6/12/325-4-125 | 155.0 | 125 | 17 | 10 | 320 |
| 45 | 1.5 | LTAISP6/15/325-4-125 | 165.0 | 125 | 13 | 14 | 320 |
| 70 | 1.5 | LTAISP6/18/425-4-125 | 305.0 | 125 | 7 | 20 | 425 |
| 90 | 1.5 | LTAISP8/20/525-4-125 | 405.0 | 125 | 6 | 21 | 400 |
| 100 | 1.5 | LTAISP10/22/625-4-125 | 550.0 | 125 | 6 | 21 | 380 |

| 4 x 25 mm ² , Ø= 27.1 mm, 1.27 kg/m, Tensile Force of Cable max. 2500 N, with reinforced Drum Body | | | | | | | |
|--|-------|-----------------------|-------------|-----|--------|-------|--------|
| l (m) | h (m) | Type Series | Weight (kg) | A | nv.(U) | n.(U) | TF.(N) |
| 22 | 1.5 | LTAISP6/12/325-4-150 | 155.0 | 150 | 19 | 8 | 320 |
| 40 | 1.5 | LTAISP6/15/325-4-150 | 165.0 | 150 | 14 | 13 | 320 |
| 65 | 1.5 | LTAISP6/18/425-4-150 | 305.0 | 150 | 9 | 18 | 420 |
| 85 | 1.5 | LTAISP8/20/525-4-150 | 405.0 | 150 | 8 | 19 | 400 |
| 95 | 1.5 | LTAISP10/22/625-4-150 | 550.0 | 150 | 8 | 19 | 380 |



Spring Cable reeling Drums, spiral, horizontal, v= 60 m/min

Type Series LTSP, LTAISP, LTAISP



Type Series LTAISP and LTAISP

4 x 35 mm², Ø= 29.7 mm, 1.72 kg/m, Tensile Force of Cable max. 2500 N,
with reinforced Drum Body

| l (m) | h (m) | Type Series | Weight (kg) | A | nv.(U) | n.(U) | TF.(N) |
|-------|-------|-----------------------|-------------|-----|--------|-------|--------|
| 30 | 1.5 | LTAISP6/15/525-4-150 | 165.0 | 150 | 17 | 10 | 530 |
| 45 | 1.5 | LTAISP8/18/525-4-150 | 380.0 | 150 | 15 | 12 | 400 |
| 55 | 1.5 | LTAISP8/20/525-4-150 | 405.0 | 150 | 13 | 14 | 400 |
| 80 | 1.5 | LTAISP10/22/625-4-150 | 550.0 | 150 | 11 | 16 | 380 |

4 x 50 mm², Ø= 35.1 mm, 2.63 kg/m, Tensile Force of Cable max. 3000 N,
with reinforced Drum Body

| l (m) | h (m) | Type Series | Weight (kg) | A | nv.(U) | n.(U) | TF.(N) |
|-------|-------|-----------------------|-------------|-----|--------|-------|--------|
| 25 | 1.5 | LTAISP8/15/625-4-220 | 165.0 | 220 | 20 | 7 | 480 |
| 40 | 1.5 | LTAISP8/18/625-4-220 | 380.0 | 220 | 20 | 10 | 480 |
| 50 | 1.5 | LTAISP8/20/625-4-220 | 405.0 | 220 | 15 | 12 | 480 |
| 65 | 1.5 | LTAISP10/22/625-4-220 | 550.0 | 220 | 14 | 13 | 480 |



Dimension Sheets LTSP, LTAISP, LTAIISP

| Type Series | Drawing No. | Ø D | Ø d | Ø f | b | k | ~a | c | Ø g | Ø h | k | i |
|-------------|-------------|------|-----|-----|-----------------------|----|-----|-----|-----|-----|----|----|
| LTSP 2 | 01-103-00-4 | 600 | 285 | 220 | Cable Ø + (3 - 5%) | 9 | 130 | 80 | 100 | 130 | 14 | 20 |
| LTSP 3 | 01-103-00-4 | 900 | 350 | 300 | | 15 | 184 | 125 | 100 | 135 | 15 | 20 |
| LTSP 4 | 01-103-00-4 | 1000 | 420 | 420 | | 20 | 237 | 165 | 130 | 178 | 18 | 23 |

Dimension c in mm = 3 + earth

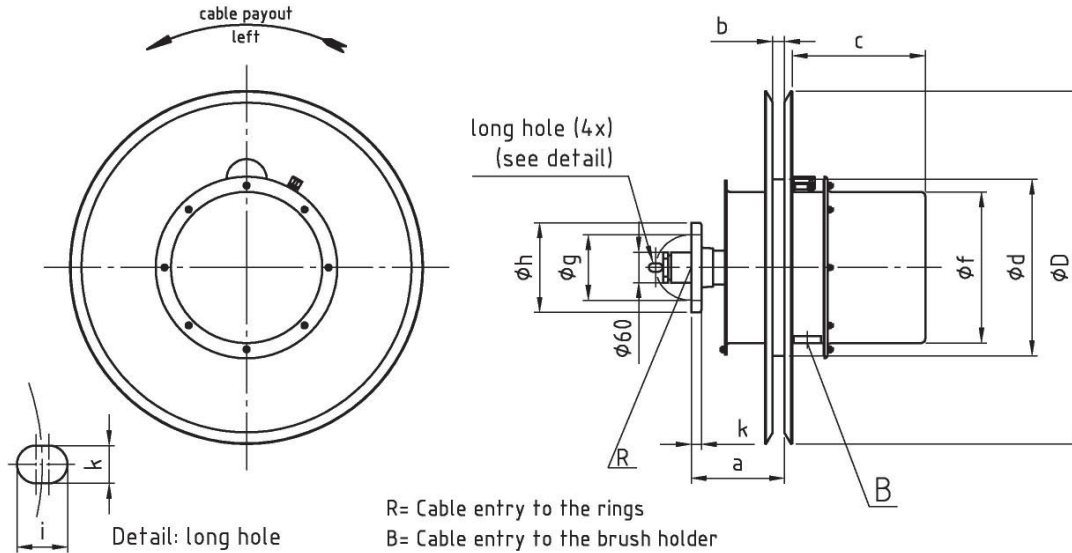

| Type Series | Drawing No. | Ø D | Ø d | a | b | c | e | f | m |
|--------------|--------------|------|------|-----|-----------------------|-----|-----|-----|-----|
| LTAISP 6/12 | 02-69-00-000 | 1200 | 600 | 260 | Cable Ø + (3 - 5%) | 446 | 112 | 385 | 260 |
| LTAISP 6/15 | 02-69-00-000 | 1500 | 600 | 260 | | 446 | 112 | 488 | 260 |
| LTAISP 6/12 | 02-69-00-000 | 1200 | 600 | 390 | | 446 | 112 | 488 | 260 |
| LTAISP 8/20 | 02-69-00-000 | 2000 | 800 | 390 | | 446 | 112 | 488 | 260 |
| LTAISP 10/22 | 02-69-00-000 | 2200 | 1000 | 390 | | 446 | 112 | 488 | 260 |

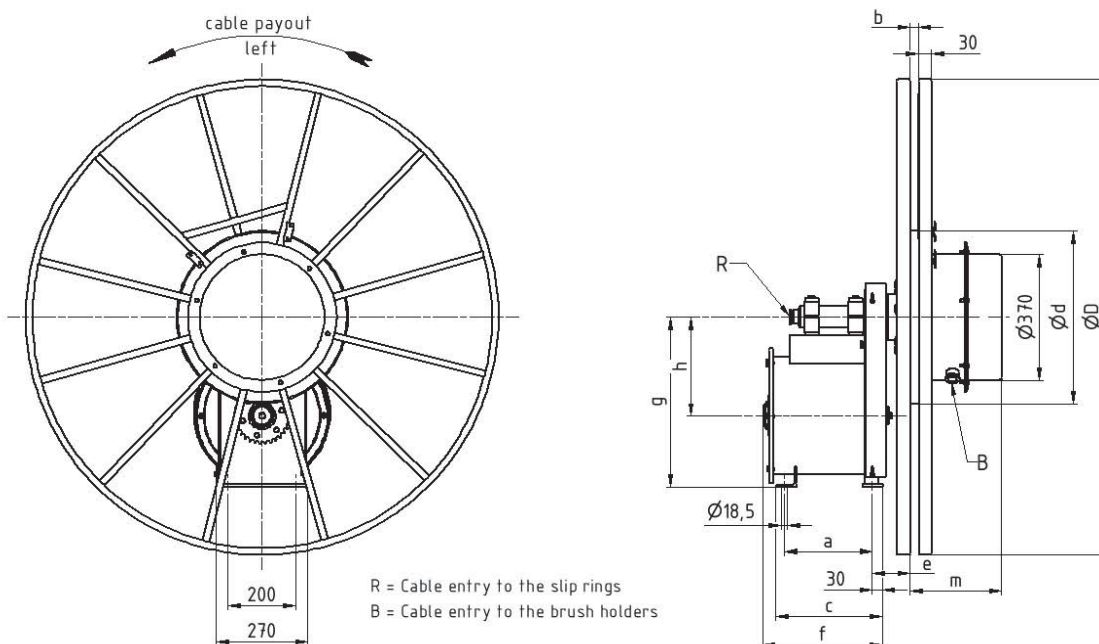



Spring Cable reeling Drums, cylindrical, horizontal, v= 60 m/min Type Series LTB, LTB....SP

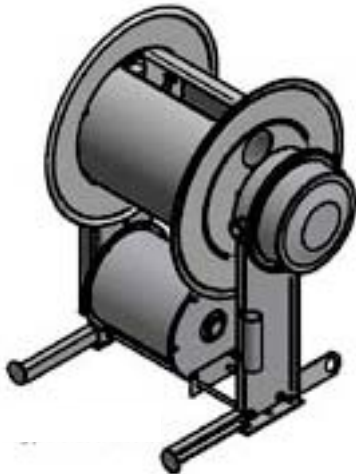

Type Series LTB

| 4 x 10 mm ² , Ø= 23.6 mm, 0.9 kg/m, Tensile Force of Cable max. 800 N | | | | | | | |
|--|-------|----------------|-------------|----|--------|-------|--------|
| l (m) | h (m) | Type Series | Weight (kg) | A | nv.(U) | n.(U) | TF.(N) |
| 60 | 1.0 | LTB50/424-4-60 | 180.0 | 60 | 10 | 34 | 190 |
| 75 | 1.0 | LTB50/524-4-60 | 190.0 | 60 | 5 | 41 | 240 |
| 100 | 1.0 | LTB50/624-4-60 | 200.0 | 60 | 6 | 55 | 210 |

| 4 x 16 mm ² , Ø= 26.7 mm, 1.24 kg/m, Tensile Force of Cable max. 1280 N | | | | | | | |
|--|-------|-----------------|-------------|-----|--------|-------|--------|
| l (m) | h (m) | Type Series | Weight (kg) | A | nv.(U) | n.(U) | TF.(N) |
| 60 | 1.0 | LTB50/424-4-125 | 180.0 | 125 | 11 | 33 | 180 |
| 75 | 1.0 | LTB50/524-4-125 | 190.0 | 125 | 5 | 40 | 230 |
| 100 | 1.0 | LTB50/624-4-125 | 200.0 | 125 | 9 | 52 | 210 |

| 4 x 25 mm ² , Ø= 31.5 mm, 1.85 kg/m, Tensile Force of Cable max. 2000 N | | | | | | | |
|--|-------|-----------------|-------------|-----|--------|-------|--------|
| l (m) | h (m) | Type Series | Weight (kg) | A | nv.(U) | n.(U) | TF.(N) |
| 60 | 1.0 | LTB50/524-4-150 | 190.0 | 150 | 12 | 32 | 230 |
| 75 | 1.0 | LTB50/624-4-150 | 220.0 | 150 | 6 | 39 | 280 |

| 4 x 35 mm ² , Ø= 42.5 mm, 2.57 kg/m, Tensile Force of Cable max. 2800 N | | | | | | | |
|--|-------|-----------------|-------------|-----|--------|-------|--------|
| l (m) | h (m) | Type Series | Weight (kg) | A | nv.(U) | n.(U) | TF.(N) |
| 60 | 1.0 | LTB50/524-4-150 | 190.0 | 150 | 13 | 31 | 230 |
| 75 | 1.0 | LTB50/624-4-150 | 220.0 | 150 | 7 | 37 | 230 |

| 4 x 50 mm ² , Ø= 49.0 mm, 3.6 kg/m, Tensile Force of Cable max. 2800 N | | | | | | | |
|---|-------|-----------------|-------------|-----|--------|-------|--------|
| l (m) | h (m) | Type Series | Weight (kg) | A | nv.(U) | n.(U) | TF.(N) |
| 60 | 1.0 | LTB50/524-4-220 | 190.0 | 150 | 13 | 31 | 230 |
| 75 | 1.0 | LTB50/624-4-220 | 220.0 | 150 | 7 | 37 | 230 |



Type Series LTB....SP

| 4 x 10 mm ² , Ø= 23.6 mm, 0.9 kg/m, Tensile Force of Cable max. 800 N | | | | | | | |
|--|-------|-----------------|-------------|----|--------|-------|--------|
| l (m) | h (m) | Type Series | Weight (kg) | A | nv.(U) | n.(U) | TF.(N) |
| 60 | 1.0 | LTB50/424SP4-60 | 230.0 | 60 | 10 | 34 | 190 |
| 75 | 1.0 | LTB50/524SP4-60 | 240.0 | 60 | 5 | 41 | 240 |
| 100 | 1.0 | LTB50/624SP4-60 | 250.0 | 60 | 6 | 55 | 210 |

| 4 x 16 mm ² , Ø= 26.7 mm, 1.24 kg/m, Tensile Force of Cable max. 1280 N | | | | | | | |
|--|-------|------------------|-------------|-----|--------|-------|--------|
| l (m) | h (m) | Type Series | Weight (kg) | A | nv.(U) | n.(U) | TF.(N) |
| 50 | 1.0 | LTB50/524SP4-125 | 230.0 | 125 | 11 | 33 | 180 |
| 75 | 1.0 | LTB50/524SP4-125 | 240.0 | 125 | 5 | 40 | 230 |
| 100 | 1.0 | LTB50/624SP4-125 | 250.0 | 125 | 9 | 52 | 210 |

| 4 x 25 mm ² , Ø= 31.5 mm, 2.57 kg/m, Tensile Force of Cable max. 2000 N | | | | | | | |
|--|-------|------------------|-------------|-----|--------|-------|--------|
| l (m) | h (m) | Type Series | Weight (kg) | A | nv.(U) | n.(U) | TF.(N) |
| 60 | 1.0 | LTB50/624SP4-150 | 240.0 | 150 | 12 | 32 | 230 |
| 75 | 1.0 | LTB50/625SP4-150 | 250.0 | 150 | 6 | 39 | 280 |

| 4 x 35 mm ² , Ø=42.5 mm, 2.57 kg/m, Tensile Force of Cable max. 2800 N | | | | | | | |
|---|-------|------------------|-------------|-----|--------|-------|--------|
| l (m) | h (m) | Type Series | Weight (kg) | A | nv.(U) | n.(U) | TF.(N) |
| 60 | 1.0 | LTB50/624SP4-150 | 240.0 | 150 | 13 | 31 | 230 |
| 75 | 1.0 | LTB50/625SP4-150 | 250.0 | 150 | 7 | 37 | 280 |

| 4 x 50 mm ² , Ø= 49.0 mm, 3.6 kg/m, Tensile Force of Cable max. 2800 N | | | | | | | |
|---|-------|------------------|-------------|-----|--------|-------|--------|
| l (m) | h (m) | Type Series | Weight (kg) | A | nv.(U) | n.(U) | TF.(N) |
| 60 | 1.0 | LTB50/624SP4-220 | 240.0 | 150 | 13 | 31 | 230 |
| 75 | 1.0 | LTB50/625SP4-220 | 250.0 | 150 | 7 | 37 | 280 |



Spring Cable reeling Drums, cylindrical, horizontal, v= 60 m/min

Type Series LTSCH, LTAISCH, LTAISCH

Spring-loaded hose reeling drums are of the same version as the cable reeling drums of type series LT and LTAI - II from page 5 - 18, however, with the difference that instead of a current consumer, a corresponding rotary valve (rotor) for air, water, gas, oil, etc., is installed.

The rotary valves that we install as standard are suitable for air and water of max. 10 bar. Higher pressures, negative pressures (vacuum), other liquids, such as hydraulic – oils, acids, alkaline solutions, etc. gases and oils must be requested separately. With a drum-reeled hose, attention must be paid to stiffness due to coiling. For manual operation, the hose can be blocked in the desired length by using a hand crank and an additional retainer.

An attachment of a roller deflector yoke allows one to smoothly coil - and uncoil the hose. Hand crank, retainer and roller yoke are available for extra payment. When selecting the appropriate hose, please pay attention to the smallest possible bending diameter as well as the tensile force specified for a spring-loaded hose reeling drum. On request, we supply also installed spiral leaf springs with particularly quiet running characteristic (noise level insulation).



Type Series LTSCH

| rigid, tough, drum-reeled, mechanically reinforced Hose, NS= 3.2 mm, G1/8", Ø= 9.5 mm | | | | | | | |
|--|-------|----------|---------------------|-------------|--------|-------|--------|
| l (m) | h (m) | Pressure | Type Series | Weight (kg) | nv.(U) | n.(U) | TF.(N) |
| 6 | 0.5 | 10bar | LTSCH155/108-1/8" | 3.1 | 3 | 12 | 40 |
| 12 | 0.5 | 10bar | LTSCH155/208H1/8" | 3.7 | 4 | 22 | 40 |
| 22 | 0.5 | 10bar | LTSCH180/231H1/8" | 11.5 | 4 | 34 | 60 |
| 24 | 0.5 | 10bar | LTSCH220/251H1/8" | 19.0 | 6 | 30 | 60 |
| 36 | 0.5 | 10bar | LTSCH300/252H1/8" | 28.0 | 3 | 36 | 100 |
| 52 | 1.5 | 10bar | LTSCH420/283H1/8" | 56.0 | 6 | 38 | 140 |
| 60 | 1.5 | 10bar | LTSCH420/253H1/8" | 57.0 | 8 | 43 | 110 |
| 75 | 1.5 | 10bar | LTSCH530/285H1/8" | 110.0 | 6 | 44 | 120 |
| 82 | 1.5 | 10bar | LTAISCH530/324-1/8" | 135.0 | 14 | 48 | 120 |
| 95 | 1.5 | 10bar | LTAISCH531/324-1/8" | 154.0 | 5 | 57 | 120 |



Type Series LTAISCH and LTAISCH

| rigid, tough, drum-reeled, mechanically reinforced Hose, NS= 6.4 mm, G1/4", Ø= 15.0 mm | | | | | | | |
|---|-------|----------|---------------------|-------------|--------|-------|--------|
| l (m) | h (m) | Pressure | Type Series | Weight (kg) | nv.(U) | n.(U) | TF.(N) |
| 10 | 0.5 | 10bar | LTSCH180/231-1/4" | 11.5 | 2 | 16 | 105 |
| 14 | 0.5 | 10bar | LTSCH220/151-1/4" | 17.0 | 2 | 18 | 100 |
| 22 | 0.5 | 10bar | LTSCH221/251H1/4" | 21.0 | 7 | 27 | 100 |
| 32 | 0.5 | 10bar | LTSCH300/252H1/4" | 28.0 | 10 | 29 | 100 |
| 33 | 1.5 | 10bar | LTSCH420/153-1/4" | 48.0 | 3 | 23 | 110 |
| 52 | 1.5 | 10bar | LTSCH420/283H1/4" | 56.0 | 9 | 35 | 140 |
| 58 | 1.5 | 10bar | LTSCH420/253H1/4" | 57.0 | 12 | 39 | 110 |
| 75 | 1.5 | 10bar | LTSCH530/285H1/4" | 110.0 | 8 | 42 | 120 |
| 82 | 1.5 | 10bar | LTAISCH530/324-1/4" | 134.0 | 4 | 46 | 120 |
| 95 | 1.5 | 10bar | LTAISCH531/324-1/4" | 153.0 | 9 | 53 | 120 |



Spring Cable reeling Drums, cylindrical, horizontal, v= 60 m/min

Type Series LTSCHE, LTAISCH, LTAIISCH



Type Series LTSCHE

| rigid, tough, drum-reeled, mechanically reinforced Hose, NS= 9.5 mm, G3/8", Ø= 20.0 mm | | | | | | | |
|---|-------|----------|----------------------|-------------|--------|-------|--------|
| l (m) | h (m) | Pressure | Type Series | Weight (kg) | nv.(U) | n.(U) | TF.(N) |
| 12 | 0.5 | 10bar | LTSCHE220/251-3/8" | 16.0 | 6 | 13 | 60 |
| 17 | 0.5 | 10bar | LTSCHE221/251H3/8" | 17.0 | 6 | 21 | 80 |
| 19 | 0.5 | 10bar | LTSCHE300/152-3/8" | 25.0 | 2 | 18 | 100 |
| 32 | 0.5 | 10bar | LTSCHE300/252H3/8" | 28.0 | 4 | 30 | 100 |
| 35 | 1.5 | 10bar | LTSCHE420/153-3/8" | 48.0 | 2 | 24 | 110 |
| 58 | 1.5 | 10bar | LTSCHE420/283H3/8" | 56.0 | 6 | 38 | 140 |
| 68 | 1.5 | 10bar | LTSCHE421/253H3/8" | 57.0 | 7 | 44 | 110 |
| 72 | 1.5 | 10bar | LTAISCH420/324-3/8" | 130.0 | 9 | 48 | 110 |
| 84 | 1.5 | 10bar | LTAISCH530/324-3/8" | 140.0 | 5 | 45 | 160 |
| 95 | 1.5 | 10bar | LTAISCH530/424-3/8" | 144.0 | 12 | 50 | 140 |
| 115 | 1.5 | 10bar | LTAIISCH700/424-3/8" | 184.0 | 14 | 48 | 120 |
| 125 | 1.5 | 10bar | LTAIISCH700/624-3/8" | 216.0 | 10 | 52 | 180 |

| rigid, tough, drum-reeled, mechanically reinforced Hose, NS= 12.7 mm, G1/2", Ø= 25.0 mm | | | | | | | |
|--|-------|----------|----------------------|-------------|--------|-------|--------|
| l (m) | h (m) | Pressure | Type Series | Weight (kg) | nv.(U) | n.(U) | TF.(N) |
| 18 | 0.5 | 10bar | LTSCHE300/252-1/2" | 28.0 | 4 | 16 | 200 |
| 30 | 1.5 | 10bar | LTSCHE420/283-1/2" | 55.0 | 3 | 19 | 250 |
| 35 | 1.5 | 10bar | LTSCHE420/253-1/2" | 57.0 | 4 | 22 | 200 |
| 45 | 1.5 | 10bar | LTSCHE421/283H1/2" | 61.0 | 15 | 28 | 140 |
| 50 | 1.5 | 10bar | LTSCHE421/253H1/2" | 62.0 | 18 | 33 | 110 |
| 66 | 1.5 | 10bar | LTSCHE530/286H1/2" | 131.0 | 6 | 34 | 245 |
| 80 | 1.5 | 10bar | LTAISCH530/424-1/2" | 150.0 | 8 | 41 | 200 |
| 110 | 1.5 | 10bar | LTAIISCH700/624-1/2" | 216.0 | 18 | 44 | 180 |



Type Series LTAISCH and LTAIISCH

| rigid, tough, drum-reeled, mechanically reinforced Hose, NS= 19.0 mm, G3/4", Ø= 31.0 mm | | | | | | | |
|--|-------|----------|----------------------|-------------|--------|-------|--------|
| l (m) | h (m) | Pressure | Type Series | Weight (kg) | nv.(U) | n.(U) | TF.(N) |
| 30 | 1.5 | 10bar | LTSCHE420/283-3/4" | 56.0 | 3 | 19 | 250 |
| 36 | 1.5 | 10bar | LTSCHE421/253-3/4" | 62.0 | 4 | 22 | 200 |
| 43 | 1.5 | 10bar | LTSCHE530/285-3/4" | 112.0 | 2 | 22 | 240 |
| 65 | 1.5 | 10bar | LTAISCH530/424-3/4" | 150.0 | 11 | 32 | 230 |
| 80 | 1.5 | 10bar | LTAISCH700/425-3/4" | 188.0 | 6 | 32 | 260 |
| 100 | 1.5 | 10bar | LTAIISCH700/625-3/4" | 234.0 | 5 | 39 | 340 |

| rigid, tough, drum-reeled, mechanically reinforced Hose, NS= 25.4 mm, G1", Ø= 39.0 mm | | | | | | | |
|--|-------|----------|--------------------|-------------|--------|-------|--------|
| l (m) | h (m) | Pressure | Type Series | Weight (kg) | nv.(U) | n.(U) | TF.(N) |
| 35 | 1.5 | 10bar | LTSCHE530/286-1" | 132.0 | 3 | 17 | 490 |
| 42 | 1.5 | 10bar | LTAISCH530/424-1" | 150.0 | 10 | 22 | 220 |
| 60 | 1.5 | 10bar | LTAIISCH530/624-1" | 173.0 | 13 | 30 | 290 |
| 79 | 1.5 | 10bar | LTAIISCH700/625-1" | 240.0 | 8 | 30 | 390 |

| rigid, tough, drum-reeled, mechanically reinforced Hose, NS= 31.5 mm, G1 1/4", Ø= 47.0 mm | | | | | | | |
|--|-------|----------|------------------------|-------------|--------|-------|--------|
| l (m) | h (m) | Pressure | Type Series | Weight (kg) | nv.(U) | n.(U) | TF.(N) |
| 36 | 1.5 | 10bar | LTAISCH530/425-1 1/4" | 165.0 | 10 | 17 | 280 |
| 53 | 1.5 | 10bar | LTAIISCH700/625-1 1/4" | 240.0 | 7 | 20 | 540 |



Dimension Sheets LTSCH, LTAISCH, LTAIISCH

| Type Series | Drawing No. | $\varnothing d$ | $\varnothing D$ | b | a | $\varnothing g$ | $\varnothing h$ | $\varnothing i$ | k |
|-------------|--------------|-----------------|-----------------|-----|-------|-----------------|-----------------|----------------------|----|
| LTSCH 155 | 02-68-00-0-4 | 155 | 260 | 110 | 101.5 | 65 | 85 | 4 x $\varnothing 09$ | 10 |
| LTSCH 180 | 02-68-00-0-4 | 180 | 300 | 130 | 113 | 65 | 85 | 4 x $\varnothing 09$ | 10 |
| LTSCH 220 | 02-68-00-0-4 | 220 | 400 | 120 | 114 | 100 | 130 | 4 x $\varnothing 13$ | 9 |
| LTSCH 221 | 02-68-00-0-4 | 220 | 450 | 150 | 129 | 100 | 130 | 4 x $\varnothing 13$ | 9 |
| LTSCH 300 | 02-68-00-0-4 | 300 | 550 | 190 | 165 | 100 | 135 | 4 x $\varnothing 15$ | 15 |
| LTSCH 420 | 02-68-00-0-4 | 420 | 680 | 240 | 200 | 130 | 178 | 4 x $\varnothing 17$ | 20 |
| LTSCH 421 | 02-68-00-0-4 | 420 | 770 | 240 | 200 | 170 | 215 | 4 x $\varnothing 17$ | 20 |
| LTSCH 530 | 02-68-00-0-4 | 530 | 900 | 310 | 260 | 200 | 250 | 4 x $\varnothing 18$ | 23 |

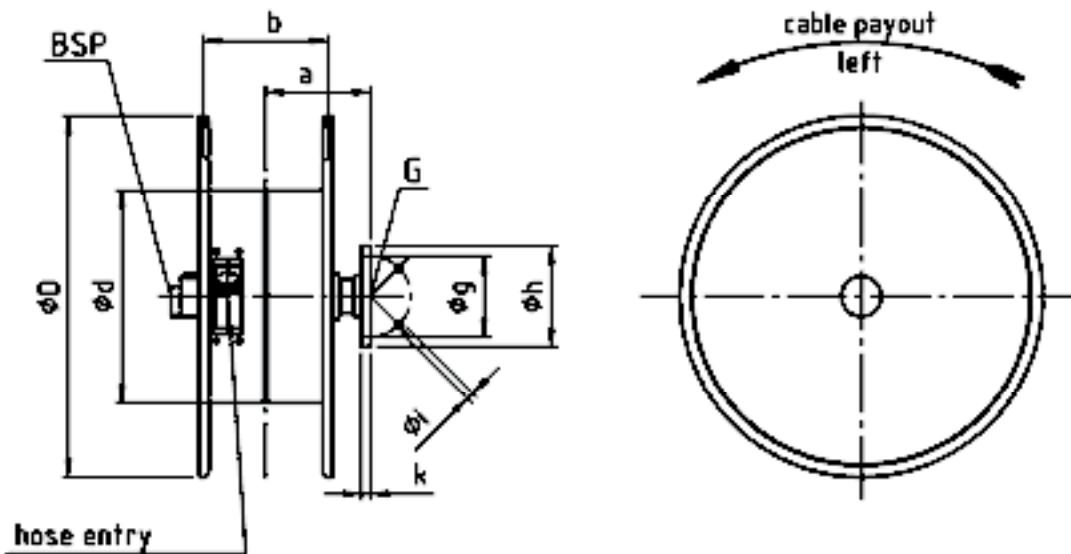

| Type Series | Drawing No. | $\varnothing d$ | $\varnothing D$ | b | a | c | e | f | g | h |
|--------------|--------------|-----------------|-----------------|-----|-----|-----|-----|-----|-----|-----|
| LTAISCH 420 | 02-67-00-0-4 | 420 | 680 | 240 | 200 | 320 | 206 | 358 | 500 | 290 |
| LTAISCH 530 | 02-67-00-0-4 | 530 | 900 | 310 | 260 | 315 | 241 | 358 | 500 | 290 |
| LTAISCH 700 | 02-67-00-0-4 | 700 | 1200 | 350 | 260 | 315 | 255 | 358 | 500 | 290 |
| LTAIISCH 530 | 02-67-00-0-4 | 530 | 900 | 310 | 260 | 445 | 241 | 488 | 50 | 290 |
| LTAIISCH 700 | 02-67-00-0-4 | 700 | 1200 | 350 | 260 | 445 | 255 | 488 | 500 | 290 |

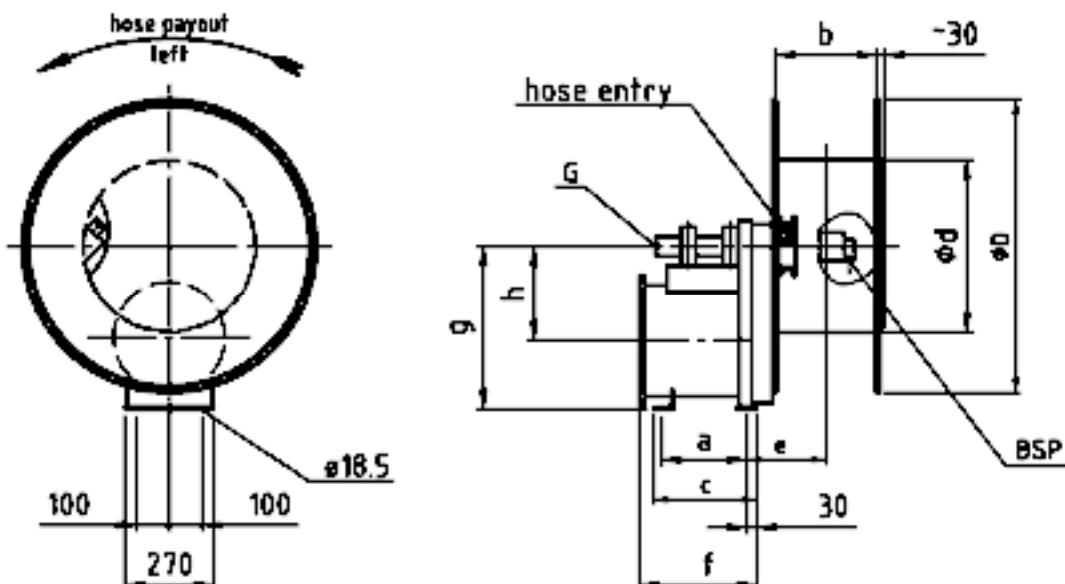



Spring Cable reeling Drums slipringless, horizontal, v= 60 m/min Type Series LTS

For slip-ring-free cable reeling drums, the special cable to be coiled is without movable contacts (slip ring body) between the two cable ends. Drums of this kind are hence particularly suitable for coiling measuring lines, multiple-wire lines (control lines) and sheathed cables. Since no movable slip ring contacts are located between the two cable ends when coiling, no special attest is required for the application of this drum in rooms with explosion protection. The drum consists of the drum body, the two auxiliary drums, the revolving roller arm with deflector pulleys, the counterweight and the drive unit as well. The drive takes place through spiral leaf springs. For cable payout from the main drum, coiling occurs by means of the revolving roller arm via the deflector pulley, the auxiliary cable, from the one to the other auxiliary drum (and vice versa, when coiling). Due to this double coiling process, the cable cannot be twisted. Attention should be paid so that non-rotating cables are used. The revolving roller arm is firmly connected with the drive axis, whereas the main drum and the auxiliary drum are mounted on the drive axle by means of bearings. A rotation on the main drum corresponds to a half rotation on the roller arm. Due to the necessary auxiliary windings, the total cable length is +75 % of the payout length. Cable diameter and cable weight are decisive for the length that can be coiled. The suitable drum type can be selected according to the above data. When placing an order, data such as type, diameter, weight and length of drum-reeled cable, must be specified since they have to be provided on the type plate.



Type Series LTS

| drum-reeled special Cable Ø= 12.0 mm, 0.25 kg/m | | | | | | | | |
|---|--------------|--------|--------------|--------|-------------|--------|-------|--------|
| Type Series | Cable Payout | | Cable Length | | Weight (kg) | nv.(U) | n.(U) | TF.(N) |
| | Hori. | Verti. | Hori. | Verti. | | | | |
| LTS25/351 | 24 | 22 | 38 | 35 | 52.0 | 4 | 26 | 90 |
| LTS35/224 | 40 | 35 | 64 | 56 | 110.0 | 8 | 32 | 130 |
| LTS45/324 | 60 | 40 | 96 | 64 | 150.0 | 4 | 36 | 150 |

| drum-reeled special Cable Ø= 16.0 mm, 0.45 kg/m | | | | | | | | |
|---|--------------|--------|--------------|--------|-------------|--------|-------|--------|
| Type Series | Cable Payout | | Cable Length | | Weight (kg) | nv.(U) | n.(U) | TF.(N) |
| | Hori. | Verti. | Hori. | Verti. | | | | |
| LTS35/224 | 35 | 20 | 56 | 32 | 110.0 | 15 | 25 | 130 |
| LTS45/324 | 45 | 25 | 72 | 40 | 150.0 | 13 | 27 | 150 |
| LTS45/424 | 55 | 33 | 88 | 52 | 160.0 | 8 | 32 | 190 |

| drum-reeled special Cable Ø= 20.0 mm, 0.65 kg/m | | | | | | | | |
|---|--------------|--------|--------------|--------|-------------|--------|-------|--------|
| Type Series | Cable Payout | | Cable Length | | Weight (kg) | nv.(U) | n.(U) | TF.(N) |
| | Hori. | Verti. | Hori. | Verti. | | | | |
| LTS35/224 | 34 | 15 | 55 | 24 | 110.0 | 17 | 23 | 130 |
| LTS45/324 | 40 | 20 | 64 | 32 | 150.0 | 17 | 23 | 150 |
| LTS45/424 | 45 | 25 | 72 | 40 | 160.0 | 14 | 26 | 190 |

| drum-reeled special Cable Ø= 21.5 mm, 1.2 kg/m | | | | | | | | |
|--|--------------|--------|--------------|--------|-------------|--------|-------|--------|
| Type Series | Cable Payout | | Cable Length | | Weight (kg) | nv.(U) | n.(U) | TF.(N) |
| | Hori. | Verti. | Hori. | Verti. | | | | |
| LTS45/424 | 40 | 12 | 64 | 20 | 160.0 | 18 | 22 | 190 |



Dimension Sheet LTS

| Type Series | Drawing No. | Ø d | Ø D | a | c | b | f | g | h |
|-------------|--------------|-----|-----|-----|-----|-----|-----|----|-----|
| LTS 25 | 05-10-00-000 | 300 | 500 | 193 | 80 | 387 | 85 | 40 | 7.5 |
| LTS 35 | 05-01-01-000 | 380 | 650 | 218 | 110 | 440 | 200 | 35 | 7.5 |
| LTS 45 | 05-02-01-000 | 500 | 800 | 245 | 160 | 515 | 200 | 35 | 7.5 |

| Type Series | Drawing No. | i | k | ~l | m | n | o | p | Ø r |
|-------------|--------------|----|-----|-----|-----|-----|-----|-----|-----|
| LTS 25 | 05-10-00-000 | -- | 145 | 560 | 220 | 300 | 160 | 430 | 214 |
| LTS 35 | 05-01-01-000 | 55 | 60 | 755 | 200 | 270 | 210 | 480 | 244 |
| LTS 45 | 05-02-01-000 | 55 | 60 | 855 | 200 | 270 | 210 | 595 | 244 |

Payout direction - right - viewed from drum body.

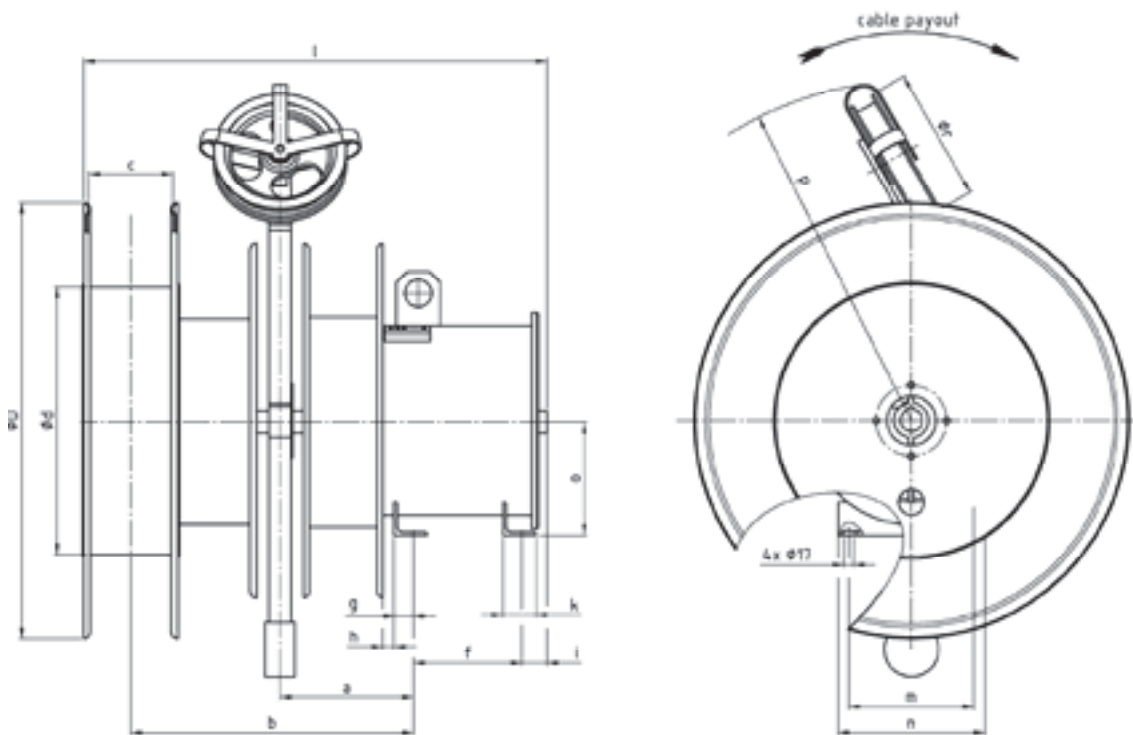



Cable reeling Drums for Counter-Weight Drive, horizontal, spiral Type Series KTGI, KTGII, KTGIII

Type series KTG is driven with a counterweight. The cable reeling drum can be used economically everywhere, where the space needed for the counterweight and the counterweight suspension is available. The counterweight distance may be shortened by suspending the counterweight in block and tackle principle, but the counterweight must be enlarged accordingly. Also for these cable reeling drums, it is possible to pay out the cable in two sides. Counterweight drums are characterised by great operational safety, since they possess few abrasive parts in the drive unit. The counterweights and flexible steel ropes must be provided by the customer. The counterweight distance travelled (rope distance in m) according to our calculation is without inward movement. To determine the counterweight and counterweight distance travelled, we request for your enquiry. Cladding and safety measures are according to accident prevention regulations.

1. KTG I cable reeling drum with flange fastening is made with an outside diameter of 1.800 mm. The rope groove body is cylindrically designed.

2. KTG II cable reeling drum is stable and equipped with a strongly conically held rope groove body. This has the advantage that with an increase in coiling diameter of the drum body also the coiling diameter of the rope body increases. This provides a nearly constant tension in the cable.

3. KTG III cable reeling drum can be made for great cable cross-sections and up to an outside diameter of the drum body of approx. 5.000 mm. The rope groove body is cylindrically designed. Drum body is equipped with several, reinforced spokes.



Type Series KTGIII

| 4 x 4 mm ² , Ø= 18.0 mm, 0.46 kg/m, Tensile Force of Cable for KTG max. 480 N v= 60 m/min, Mounting Height 1.5 m | | | | | | | | | |
|--|---------------|----|-------------|------------------|-------------|--------|-------|--------|---------------------|
| Length (m) | Type Series | A | Rope Ø (mm) | Rope Length* (m) | Weight (kg) | nv.(U) | n.(U) | TF.(N) | Counter Weight (kg) |
| 40 | KTGI6/12-4-60 | 60 | 6 | 7.5 | 125.0 | 2.0 | 14.0 | 240 | 87.8 |
| 60 | KTGI6/15-4-60 | 60 | 6 | 10.0 | 130.0 | 2.0 | 19.0 | 275 | 100.6 |

| 4 x 6 mm ² , Ø= 19.4 mm, 0.58 kg/m, Tensile Force of Cable for KTG max. 720 N v= 60 m/min, Mounting Height 1.5 m | | | | | | | | | |
|--|---------------|----|-------------|------------------|-------------|--------|-------|--------|---------------------|
| Length (m) | Type Series | A | Rope Ø (mm) | Rope Length* (m) | Weight (kg) | nv.(U) | n.(U) | TF.(N) | Counter Weight (kg) |
| 34 | KTGI6/12-4-60 | 60 | 6 | 6.5 | 125.0 | 2.0 | 12.0 | 260 | 95.1 |
| 64 | KTGI6/15-4-60 | 60 | 6 | 10.5 | 130.0 | 2.0 | 19.0 | 285 | 104.2 |
| 80 | KTGI8/18-4-60 | 60 | 6 | 10.5 | 225.0 | 2.0 | 20.0 | 320 | 156.1 |

| 4 x 10 mm ² , Ø= 23.6 mm, 0.91 kg/m, Tensile Force of Cable for KTG max. 1200 N v= 60 m/min, Mounting Height 1.5 m | | | | | | | | | |
|--|---------------|----|-------------|------------------|-------------|--------|-------|--------|---------------------|
| Length (m) | Type Series | A | Rope Ø (mm) | Rope Length* (m) | Weight (kg) | nv.(U) | n.(U) | TF.(N) | Counter Weight (kg) |
| 28 | KTGI6/12-4-60 | 60 | 6 | 5.5 | 125.0 | 2.0 | 9.6 | 420 | 153.7 |
| 55 | KTGI6/15-4-60 | 60 | 6 | 9.0 | 130.0 | 2.0 | 16.3 | 440 | 161.0 |
| 75 | KTGI8/18-4-60 | 60 | 6 | 10.0 | 225.0 | 2.0 | 18.0 | 460 | 224.4 |

| 4 x 16 mm ² , Ø= 26.7 mm, 1.24 kg/m, Tensile Force of Cable for KTG max. 1920 N v= 60 m/min, Mounting Height 1.5 m | | | | | | | | | |
|--|----------------|-----|-------------|------------------|-------------|--------|-------|--------|---------------------|
| Length (m) | Type Series | A | Rope Ø (mm) | Rope Length* (m) | Weight (kg) | nv.(U) | n.(U) | TF.(N) | Counter Weight (kg) |
| 23 | KTGI6/12-4-125 | 125 | 6 | 4.5 | 125.0 | 2.0 | 7.9 | 640 | 234.1 |
| 47 | KTGI6/15-4-125 | 125 | 6 | 7.5 | 130.0 | 2.0 | 14.0 | 660 | 241.5 |
| 65 | KTGI8/18-4-125 | 125 | 6 | 8.5 | 225.0 | 2.0 | 16.0 | 680 | 331.7 |
| 80 | KTGI8/20-4-125 | 125 | 8 | 13.0 | 265.0 | 2.0 | 18.2 | 700 | 265.0 |



Cable reeling Drums for Counter-Weight Drive, horizontal, spiral Type Series KTGI, KTGII, KTGIII



Type Series KTGIII

| 4 x 25 mm ² , Ø=27.1 mm, 1.27 kg/m, Tensile Force of Cable for KTG max. 3000 N v= 60 m/min, Mounting Height 1.5 m | | | | | | | | | |
|---|------------------|-----|-------------|------------------|-------------|--------|-------|--------|---------------------|
| Length (m) | Type Series | A | Rope Ø (mm) | Rope Length* (m) | Weight (kg) | nv.(U) | n.(U) | TF.(N) | Counter Weight (kg) |
| 20 | KTGI6/12-4-150 | 150 | 6 | 4.0 | 130.0 | 2.0 | 6.8 | 800 | 293.0 |
| 40 | KTGI6/15-4-150 | 150 | 6 | 6.5 | 135.0 | 2.0 | 12.2 | 820 | 300.0 |
| 54 | KTGII8/18-4-150 | 150 | 6 | 9.0 | 225.0 | 2.0 | 12.9 | 840 | 314.1 |
| 75 | KTGII8/20-4-150 | 150 | 8 | 11.5 | 265.0 | 2.0 | 16.6 | 860 | 321.5 |
| 98 | KTGII10/25-4-150 | 150 | 8 | 13.0 | 375.0 | 2.0 | 18.3 | 880 | 411.2 |

| 4 x 35 mm ² , Ø= 29.7 mm, 1.72 kg/m, Tensile Force of Cable for KTG max. 3150 N v= 60 m/min, Mounting Height 1.5 m | | | | | | | | | |
|--|------------------|-----|-------------|------------------|-------------|--------|-------|--------|---------------------|
| Length (m) | Type Series | A | Rope Ø (mm) | Rope Length* (m) | Weight (kg) | nv.(U) | n.(U) | TF.(N) | Counter Weight (kg) |
| 35 | KTGI6/15-4-150 | 150 | 6 | 6.0 | 135.0 | 2.0 | 10.7 | 850 | 311.1 |
| 50 | KTGII8/18-4-150 | 150 | 6 | 9.0 | 225.0 | 2.0 | 12.4 | 870 | 325.3 |
| 63 | KTGII8/20-4-150 | 150 | 8 | 10.0 | 265.0 | 2.0 | 14.8 | 890 | 332.7 |
| 100 | KTGII10/25-4-150 | 150 | 8 | 13.0 | 375.0 | 2.0 | 18.9 | 1010 | 467.3 |

| 4 x 50 mm ² , Ø= 37.4 mm, 2.85 kg/m, Tensile Force of Cable for KTG max. 4500 N v= 60 m/min, Mounting Height 2.0 m, with reinforced Drum Body | | | | | | | | | |
|---|------------------|-----|-------------|------------------|-------------|--------|-------|--------|---------------------|
| Length (m) | Type Series | A | Rope Ø (mm) | Rope Length* (m) | Weight (kg) | nv.(U) | n.(U) | TF.(N) | Counter Weight (kg) |
| 30 | KTGI6/15-4-220 | 220 | 6 | 5.0 | 135.0 | 2.0 | 8.9 | 1020 | 373.2 |
| 43 | KTGII8/18-4-220 | 220 | 8 | 7.5 | 225.0 | 2.0 | 10.2 | 1040 | 388.8 |
| 59 | KTGII8/20-4-220 | 220 | 8 | 9.0 | 265.0 | 2.0 | 13.1 | 1060 | 396.3 |
| 95 | KTGII10/25-4-220 | 220 | 8 | 11.5 | 375.0 | 2.0 | 17.0 | 1080 | 504.7 |

| 3 x 70 + 3 x 35/3 mm ² , Ø= 42.7 mm, 3.92 kg/m, Tensile Force of Cable for KTG max. 6300 N v= 60 m/min, Mounting Height 2.0 m, with reinforced Drum Body | | | | | | | | | |
|--|-------------------|-----|-------------|------------------|-------------|--------|-------|--------|---------------------|
| Length (m) | Type Series | A | Rope Ø (mm) | Rope Length* (m) | Weight (kg) | nv.(U) | n.(U) | TF.(N) | Counter Weight (kg) |
| 36 | KTGII8/18-4-220 | 220 | 6 | 6.0 | 225.0 | 2.0 | 8.6 | 1200 | 448.6 |
| 50 | KTGII8/20-4-220 | 220 | 8 | 7.5 | 265.0 | 2.0 | 11.0 | 1220 | 456.0 |
| 80 | KTGII10/25-4-220 | 220 | 8 | 10.0 | 375.0 | 2.0 | 14.3 | 1240 | 579.4 |
| 115 | KTGIII12/30-4-220 | 220 | 12 | 16.5 | 900.0 | 2.0 | 17.3 | 1260 | 521.4 |



Cable reeling Drums for Counter-Weight Drive, horizontal, spiral Type Series KTGI, KTGII, KTGIII



Type Series KTGIII

| 3 x 95 + 3 x 50/3 mm ² , Ø= 47.3 mm, 5.02 kg/m, Tensile Force of Cable for KTG max. 8550 N v= 60 m/min, Mounting Height 2.0 m, with reinforced Drum Body | | | | | | | | | |
|--|-------------------|-----|-------------|------------------|-------------|--------|-------|--------|---------------------|
| Length (m) | Type Series | A | Rope Ø (mm) | Rope Length* (m) | Weight (kg) | nv.(U) | n.(U) | TF.(N) | Counter Weight (kg) |
| 30 | KTGII8/18-4-265 | 265 | 8 | 5.5 | 225.0 | 2.0 | 7.2 | 1300 | 486.0 |
| 45 | KTGII8/20-4-265 | 265 | 8 | 7.0 | 265.0 | 2.0 | 9.8 | 1320 | 493.5 |
| 72 | KTGII10/25-4-265 | 265 | 8 | 9.0 | 375.0 | 2.0 | 12.8 | 1340 | 626.2 |
| 105 | KTGIII12/30-4-265 | 265 | 12 | 15.0 | 900.0 | 2.0 | 15.7 | 1360 | 562.8 |

| 3 x 120 + 3 x 70/3 mm ² , Ø= 55.0 mm, 6.63 kg/m, Tensile Force of Cable for KTG max. 10000 N v= 60 m/min, Mounting Height 2.0 m, with reinforced Drum Body | | | | | | | | | |
|--|-------------------|-----|-------------|------------------|-------------|--------|-------|--------|---------------------|
| Length (m) | Type Series | A | Rope Ø (mm) | Rope Length* (m) | Weight (kg) | nv.(U) | n.(U) | TF.(N) | Counter Weight (kg) |
| 33 | KTGIII10/20-4-500 | 500 | 12 | 6.5 | 750.0 | 2.0 | 6.6 | 1400 | 482.8 |
| 60 | KTGIII10/25-4-500 | 500 | 12 | 10.0 | 800.0 | 2.0 | 10.6 | 1420 | 489.7 |
| 95 | KTGIII12/30-4-500 | 500 | 12 | 13.0 | 950.0 | 2.0 | 13.9 | 1440 | 595.9 |

| 3 x 150 + 3 x 70/3 mm ² , Ø= 57.9 mm, 7.6 kg/m, Tensile Force of Cable for KTG max. 13000 N v= 60 m/min, Mounting Height 2.0 m, with reinforced Drum Body | | | | | | | | | |
|---|--------------------|------|-------------|------------------|-------------|--------|-------|--------|---------------------|
| Length (m) | Type Series | A | Rope Ø (mm) | Rope Length* (m) | Weight (kg) | nv.(U) | n.(U) | TF.(N) | Counter Weight (kg) |
| 30 | KTGIII10/20-4-1000 | 1000 | 12 | 6.5 | 750.0 | 2.0 | 6.0 | 1500 | 517.2 |
| 55 | KTGIII10/25-4-1000 | 1000 | 12 | 9.5 | 800.0 | 2.0 | 9.7 | 1520 | 524.2 |
| 90 | KTGIII12/30-4-1000 | 1000 | 12 | 12.0 | 950.0 | 2.0 | 13.1 | 1540 | 637.2 |



Dimension Sheets KTGI, KTGII, KTGIII

| Type Series | Drawing No. | Ø D | b | 3+Earth 60 A | 3+Earth 150 A | 3+Earth 220 A | 3+Earth 265 A | 3+Earth 500 A | ~ e |
|-------------|--------------|------|-----------------------|-----------------|------------------|------------------|------------------|------------------|-----|
| KTG I 6/12 | 04-53-00-0-3 | 1200 | Cable Ø + (3 - 5%) | 280 | 280 | 280 | -- | -- | 645 |
| KTG I 6/15 | 04-53-00-0-3 | 1500 | | 280 | 280 | 280 | -- | -- | 645 |
| KTG I 8/18 | 04-53-00-0-3 | 1800 | | 280 | 280 | 280 | -- | -- | 645 |
| KTG I 8/20 | 04-53-00-0-3 | 2000 | | 280 | 280 | 280 | -- | -- | 645 |

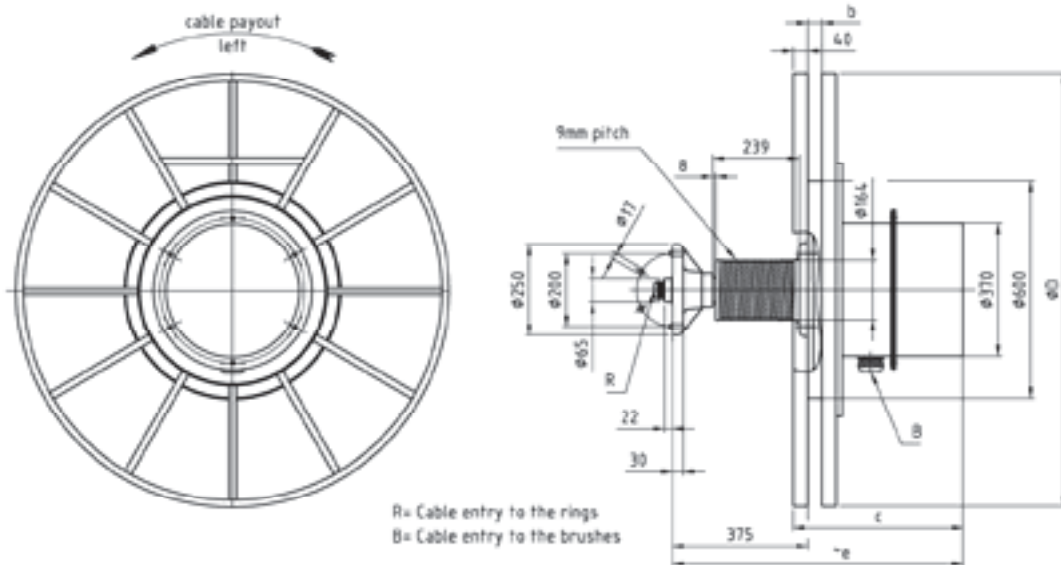

Dimension c = 3 + earth

| Type Series | Drawing No. | Ø D | b | 3+Earth 60 A | 3+Earth 150 A | 3+Earth 220 A | 3+Earth 265 A | 3+Earth 500 A | ~ e |
|-------------|--------------|------|-----------------------|-----------------|------------------|------------------|------------------|------------------|-----|
| KTG II 8/18 | 04-54-00-0-3 | 1800 | Cable Ø + (3 - 5%) | 280 | 385 | 385 | 380 | 380 | 820 |
| KTG II 8/20 | 04-54-00-0-3 | 2000 | | 280 | 385 | 385 | 380 | 380 | 820 |
| KTG II 8/25 | 04-54-00-0-3 | 2500 | | 280 | 385 | 385 | 380 | 380 | 820 |

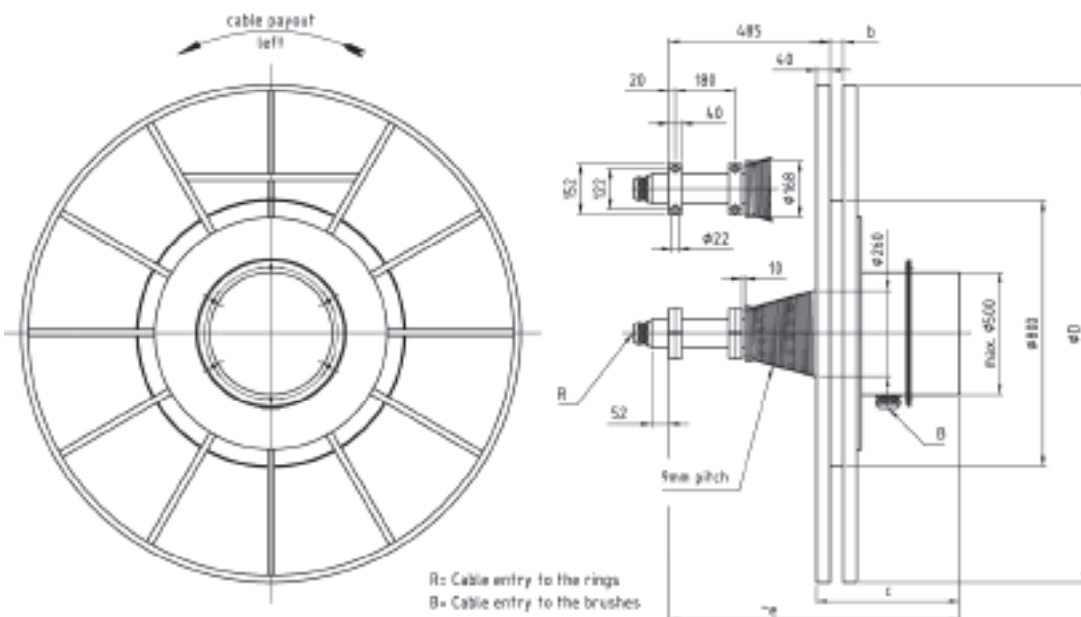

Dimension c = 3 + earth



Dimension Sheets KTGIII

| Type Series | Drawing No. | Ø d | Ø D | b | 3+Earth 60 A | 3+Earth 150 A | 3+Earth 220 A | 3+Earth 265 A | 3+Earth 500 A | ~ e |
|---------------|--------------|------|------|-----------------------|-----------------|------------------|------------------|------------------|------------------|------|
| KTG III 10/20 | 04-55-00-0-3 | 1000 | 2000 | Cable Ø + (3 - 5%) | -- | 325 | 325 | 375 | 375 | 1000 |
| KTG III 10/25 | 04-55-00-0-3 | 1000 | 2500 | | -- | 325 | 325 | 375 | 375 | 1000 |
| KTG III 12/30 | 04-55-00-0-3 | 1000 | 3000 | | -- | 325 | 325 | 375 | 375 | 1000 |

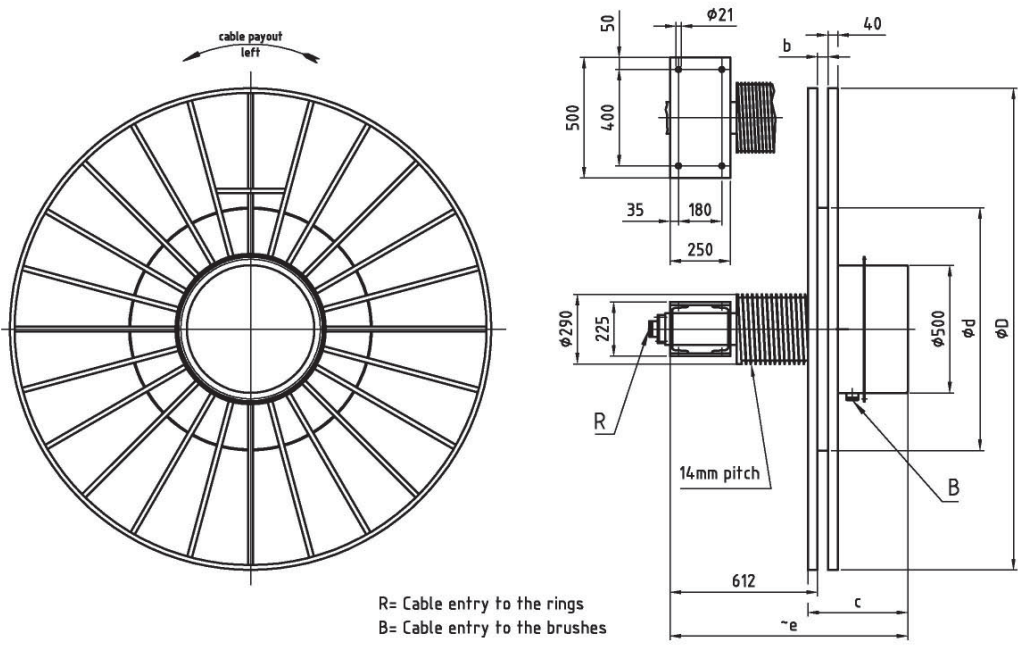

Dimension c = 3 + earth



Accessories

Ratchet (retention 1x per revolution)

With the ratchet a certain length of the cable can be secured as standard feature, with one retention position per revolution. If desired also several retention positions can be provided. Moreover, tensile relief finds application through this tension relief. The attached ratchet is on the flange, the segment piece is attached to the drum body housing. In case of later attachment of the ratchet on its cable reeling drum, you will be given the required parts with attachment instruction.



Type Serie
Ratchet (RA)

| Ratchet Type | suitable Type Series | Drawing No. |
|--------------|----------------------|--------------|
| RA 155 | LT 155 | 01-96-00-000 |
| RA 180 | LT 180 | 01-96-00-000 |
| RA 220 | LT 220 | 01-96-00-000 |
| RA 221 | LT 221 | 01-96-00-000 |
| RA 222 | LT 222 | 01-96-00-000 |
| RA 300 | LT 300 | 01-96-00-000 |
| RA 301 | LT 301 | 01-96-00-000 |
| RA 420 | LT 420 | 01-96-00-000 |
| RA 421 | LT 421 | 01-96-00-000 |
| RA 530 | LT 530 | 01-96-00-000 |

Roller Yoke

The swivelling roller yoke is installed at the flange. By the supporting of the roller yoke, uniform uncoiling and coiling of the cable is ensured and this prevents the cable from “jumping” over the outer shield of the drum. The roller yoke is equipped with plastic rollers. This makes it possible to pay out the cable smoothly and laterally. The roller yoke can be swivelled upwards and downwards.



Type Serie
Roller Yoke (R)

| Roller Yoke Type | suitable Type Series | Drawing No. |
|------------------|----------------------|--------------|
| R 155 | LT 155 | 01-97-00-000 |
| R 180 | LT 180 | 01-97-00-000 |
| R 220 | LT 220 | 01-97-00-000 |
| R 221 | LT 221 | 01-97-00-000 |
| R 222 | LT 222 | 01-97-00-000 |
| R 300 | LT 300 | 01-97-00-000 |
| R 301 | LT 301 | 01-97-00-000 |
| R 420 | LT 420 | 01-97-00-000 |
| R 421 | LT 421 | 01-97-00-000 |
| R 530 | LT 530 | 01-97-00-000 |

Eye Yoke

The swivelling eye yoke is installed at the flange. By the supporting of the eye yoke, uniform coiling and uncoiling of cable is ensured, and this prevents the cable from “jumping” over the outer shield of the drum. In contrast, application areas for this are in environments or plants where a high concentration of dirt-particles prevails, or where it must be capable of being decontaminated. The eye yoke is made of a round steel rod and it can therefore not damage the cable.



Type Serie
Eye Yoke (O)

| Eye Yoke Type | suitable Type Series | Drawing No. |
|---------------|----------------------|--------------|
| O 155 | LT 155 | 01-98-00-000 |
| O 180 | LT 180 | 01-98-00-000 |
| O 220 | LT 220 | 01-98-00-000 |
| O 221 | LT 221 | 01-98-00-000 |
| O 222 | LT 222 | 01-98-00-000 |
| O 300 | LT 300 | 01-98-00-000 |
| O 301 | LT 301 | 01-98-00-000 |
| O 420 | LT 420 | 01-98-00-000 |
| O 421 | LT 421 | 01-98-00-000 |
| O 530 | LT 530 | 01-98-00-000 |



Accessories

Rotating Ceiling Mounting Bracket

The rotating ceiling mounting bracket has a swivelling range 300° with an stopper. It is suitable for mounting under the ceiling in, e.g. workshops or automation, in order to cover a working area of max. 300°.



Type Serie
rotable Ceiling Mounting Bracket (DrD)

| rotable Ceiling Mounting Bracket Type | suitable Type Series | Drawing No. |
|---------------------------------------|----------------------|--------------|
| DrD 155 | LT 155 | 01-99-00-000 |
| DrD 180 | LT 180 | 01-99-00-000 |
| DrD 220 | LT 220 | 01-99-00-000 |
| DrD 221 | LT 221 | 01-99-00-000 |
| DrD 222 | LT 222 | 01-99-00-000 |
| DrD 300 | LT 300 | 01-99-00-000 |
| DrD 301 | LT 301 | 01-99-00-000 |
| DrD 420 | LT 420 | 01-99-00-000 |
| DrD 421 | LT 421 | 01-99-00-000 |
| DrD 530 | LT 530 | 01-99-00-000 |

Rotating Wall Mounting Bracket

The rotating wall mounting bracket has a swivelling range 150° with an stopper. It is suitable for wall mounting, e.g. workshops, in order to cover a working area of max. 150°.

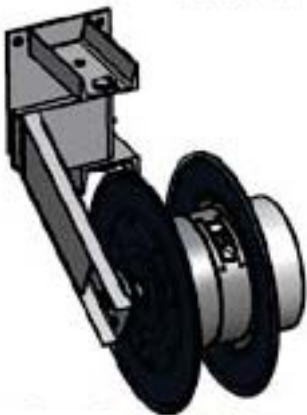

Type Serie
rotable Wall Mounting Bracket (WA)

| rotable Wall Mounting Bracket Type | suitable Type Series | Drawing No. |
|------------------------------------|----------------------|---------------|
| WA 155 | LT 155 | 01-62-03-000 |
| WA 180 | LT 180 | 01-53-03-000 |
| WA 220 | LT 220 | 01-46-03-000 |
| WA 221 | LT 221 | 01-52-03-000 |
| WA 222 | LT 222 | 01-46-03-000 |
| WA 300 | LT 300 | 01-47-03-000 |
| WA 301 | LT 301 | 01-119-00-000 |
| WA 420 | LT 420 | 01-48-03-000 |
| WA 421 | LT 421 | 01-49-03-000 |
| WA 530 | LT 530 | 01-59-03-000 |

Fixed Mounting Bracket

The fixed mounting bracket for ceiling resp. ground erection is suitable for e.g. workshops or automation.

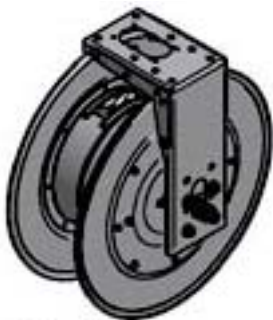

Type Serie
fixed Mounting Bracket (STB)

| fixed Mounting Bracket Type | suitable Type Series | Drawing No. |
|-----------------------------|----------------------|-------------|
| STB 155-180 | LT 155-180 | 2381-0003 |
| STB 220-301 | LT 220-301 | 2382-0006 |
| STB 420 | LT 420 | 2384-0004 |
| STB 421 | LT 421 | 2384-0004a |
| STB 530 | LT 530 | 2385-0003 |



Accessories

Double Cable Deflector Sheave Type Series UD

Double cable deflector sheave for a spiral coil. Serves for deflecting reeled cable from a higher positioned cable drum and for moving over the centre feed funnel.

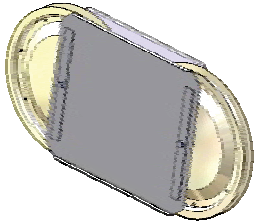

Typ Serie UD

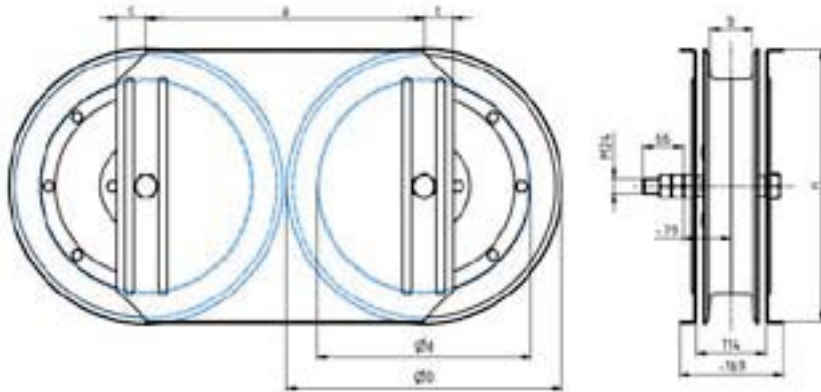

| Type Series | Drawing No. | max. Cable Ø |
|-------------|--------------|--------------|
| UD I | 13-70-00-000 | 20 mm |
| UD II | 13-71-00-000 | 30 mm |
| UD III | 13-72-00-000 | 40 mm |
| UD IV | 13-73-00-000 | 52 mm |

| Type Series | a | b | c | Ø d | Ø D | n |
|-------------|-----|----|------|-----|-----|-----|
| UD I | 455 | 70 | 47.5 | 350 | 450 | 444 |
| UD II | 655 | 70 | 50 | 530 | 650 | 640 |
| UD III | 785 | 70 | 70 | 660 | 780 | 770 |
| UD IV | 925 | 70 | 70 | 780 | 900 | 910 |

Double Cable Deflector Pulley with Cross Rollers, Type Series UDQ

Double cable deflector pulley for cylindrical coil (multi-layered) with cross rollers. It serves for deflecting drum-reeled cable from a higher positioned cable drum (similar to normal double cable reeling drum) and for passing over the centre feed funnel.

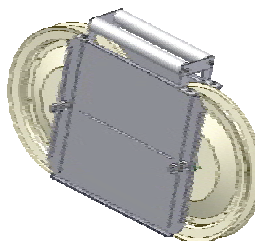

Typ Serie UDQ

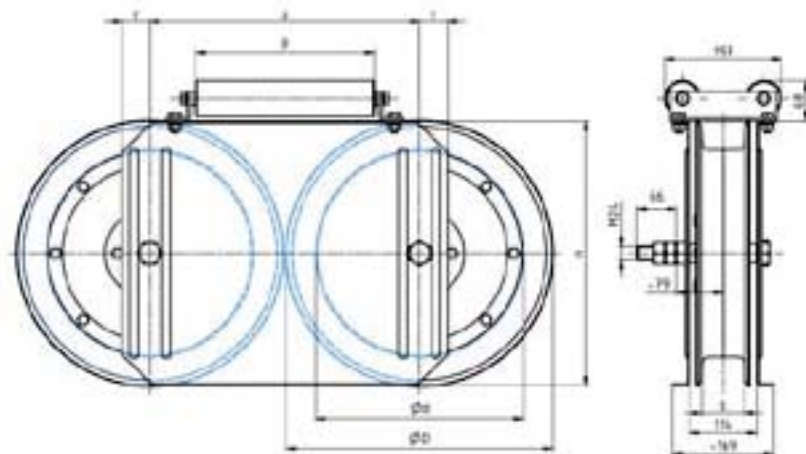

| Type Series | Drawing No. | max. Cable Ø |
|-------------|--------------|--------------|
| UDQ I | 13-70-01-000 | 22 mm |
| UDQ II | 13-71-01-000 | 30 mm |
| UDQ III | 13-72-01-000 | 40 mm |
| UDQ IV | 13-73-01-000 | 52 mm |

| Type Series | a | b | c | Ø d | Ø D | n | p |
|-------------|-----|----|------|-----|-----|-----|-----|
| UDQ I | 455 | 70 | 47.5 | 350 | 450 | 447 | 301 |
| UDQ II | 655 | 70 | 50 | 530 | 650 | 640 | 386 |
| UDQ III | 785 | 70 | 70 | 660 | 780 | 770 | 486 |
| UDQ IV | 925 | 70 | 70 | 780 | 900 | 910 | 600 |



Accessories

Double Cable Deflector Pulley, Type Series L

Double cable deflector pulley for channel with unequal deflector pulleys. The installed guide or deflector pulley serves for keeping the drum-reeled cable in a cable channel. The application must always occur laterally with the large pulley in the direction of cable reeling drum. The distance of the drum from the deflector pulley should be chosen such that only an inclination of max. 4° occurs from the drum width. We are at your disposal for more accurate information.

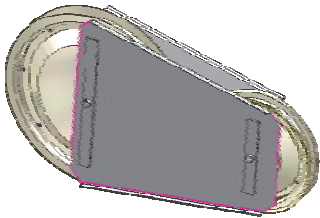

Type Serie L

| Type Series | Drawing No. | max. Cable Ø |
|-------------|--------------|--------------|
| L I | 13-67-00-000 | 30 mm |
| L II | 13-68-00-000 | 40 mm |

| Type Series | a | Ø b | Ø c | Ø d | Ø e | f | k | l |
|-------------|-----|-----|-----|-----|-----|-----|-----|----|
| L I | 790 | 350 | 450 | 530 | 650 | ~70 | 893 | 96 |
| L II | 860 | 350 | 450 | 660 | 770 | ~70 | 943 | 97 |

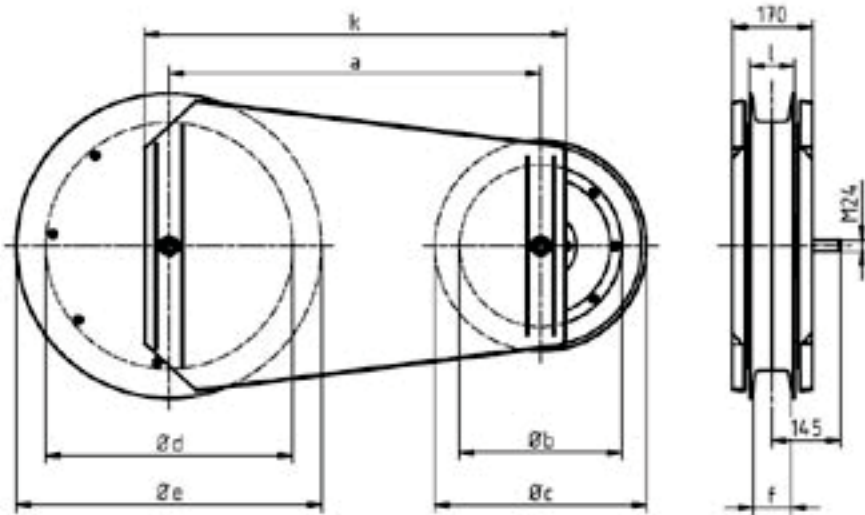

Deflector Horn

Longitudinally divided deflector horn with chain and screw fastening. The deflector horn prevents kinking of cable when running over cable fixed points. The arrangement is horizontal and as far as possible from the middle, such that it can transform without hindrance. The arrangement must occur in the middle of cable reeling drum. The deflector horn can only be installed when neither the spooling device nor the chain find application.

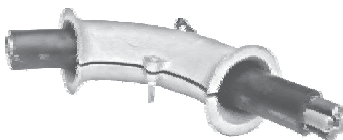

Type Serie Deflector Horn

| Type Series | Drawing No. | max. Cable Ø |
|----------------------|--------------|--------------|
| Deflector Horn - I | 13-14-00-000 | 19-22 mm |
| Deflector Horn - II | 13-15-00-000 | 23-32 mm |
| Deflector Horn - III | 13-16-00-000 | 33-40 mm |
| Deflector Horn - IV | 13-43-00-000 | 42-55 mm |



Accessories

Spooling Device, Type Series SP

Spooling device with cross spindle and guiding finger with roller chain for connection to the cable reeling drum. The attachment of the spooling device to the cable reeling drum serves for uniform coiling of the cable on a cylindrical drum body. The uniformly coiled drum body prevents the cable layers from climbing over one another, and thus from overflow of cable layers over the drum shield and subsequent damage or malfunction of cable. At the same time it preserves the cable. The version driven by chain can be retrofitted on existing systems.



Type Serie SP

| Type Series | Drawing No. | Coiling Width | max. Cable Ø |
|-------------|---------------|---------------|--------------|
| SP 590 | X03-12-00-000 | 590 mm | 50 mm |

*** Special dimensions can be worked out for you at any time, in cooperation with the customer by specifying the coiling width and the cable diameter. ***

Cable Deflector Centre Feed Funnel, Type Series ULTV

Cable deflector centre feed funnel with vertical position is suitable for cable channel shaft. The commercial deflector funnel type ULTV is generally accommodated perpendicularly in a concrete shaft for connection to the cable. It should be positioned below the cable deposit. Fastening holes are provided.



Type Serie ULTV

| Type Series | Drawing No. | max. Cable Ø |
|-------------|--------------|--------------|
| ULTV - I | 13-52-00-000 | 19 mm |
| ULTV - II | 13-47-00-000 | 21 mm |
| ULTV - III | 13-41-00-000 | 29 mm |
| ULTV - IV | 13-42-00-000 | 38 mm |

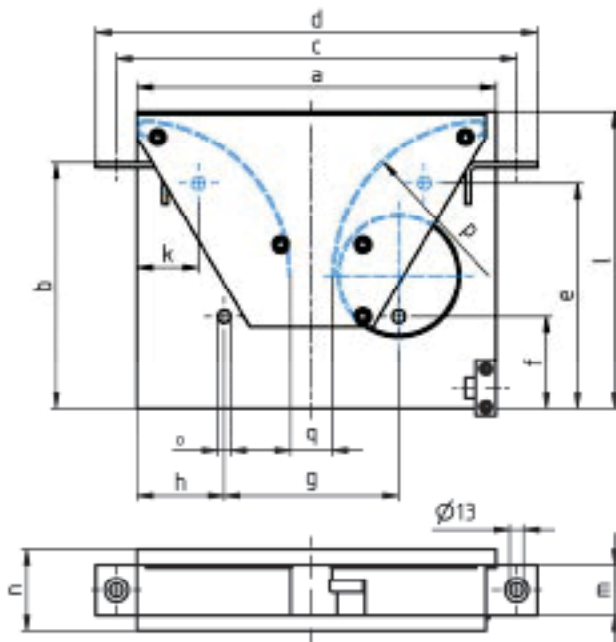

| Type Series | a | b | c | d | e | f | g | h |
|-------------|-----|-----|-----|-----|-----|-----|-----|-----|
| ULTV - I | 350 | 240 | 390 | 430 | 220 | 90 | 170 | 85 |
| ULTV - II | 425 | 270 | 465 | 505 | 220 | 78 | 202 | 98 |
| ULTV - III | 540 | 495 | 670 | 720 | 405 | 310 | 300 | 360 |
| ULTV - IV | 820 | 650 | 920 | 970 | 550 | 200 | 400 | 210 |

| Type Series | i | k | l | m | n | o | p | q |
|-------------|-----|----|-----|-----|-----|----|-----|----|
| ULTV - I | 220 | 60 | 290 | 50 | 80 | 13 | 150 | 40 |
| ULTV - II | 360 | 20 | 300 | 70 | 110 | 13 | 175 | 40 |
| ULTV - III | 400 | 70 | 530 | 100 | 140 | 13 | 270 | 55 |
| ULTV - IV | 740 | 40 | 700 | 140 | 180 | 17 | 400 | 80 |



Accessories

Deflector and Guide Pulleys, Type Series URN, LRN

Deflector and guide pulleys for cable guidance for onboard operation in marine design, according to ship classification DNV, GL, and LRS, as well as for harbour cranes. Cable deflector pulleys and guide pulleys for onboard and normal versions. They are used when the drum-reeled cable is not paid out directly from the cable reeling drum, but through cable deflections. Roller core diameters min. 15 x cable diameter.



Type Serie URN

| Type Series | Drawing No. | Drawing No. Marine Design | Weight (kg) | Ø a | Ø b | Ø c | d | e | f |
|-------------|--------------|---------------------------|-------------|-----|-----|-----|-----|----|----|
| URN 350 | 13-30-01-001 | 13-30-01-000 | 23 | 600 | 450 | 350 | 195 | 60 | 99 |
| URN 500 | 13-32-00-001 | 13-32-00-000 | 42 | 800 | 650 | 530 | 240 | 84 | 85 |
| URN 660 | 13-33-00-001 | 13-33-00-000 | 52 | 900 | 780 | 660 | 240 | 86 | 75 |

| Type Series | Drawing No. | Drawing No. Marine Design | Weight (kg) | g | h | j | k | l | m |
|-------------|--------------|---------------------------|-------------|----|------|-----|----|----|-----|
| URN 350 | 13-30-01-001 | 13-30-01-000 | 23 | 42 | M 20 | 180 | 50 | 58 | 98 |
| URN 500 | 13-32-00-001 | 13-32-00-000 | 42 | 57 | M 30 | 280 | 50 | 82 | 112 |
| URN 660 | 13-33-00-001 | 13-33-00-000 | 52 | 55 | M 30 | 344 | 70 | 90 | 120 |

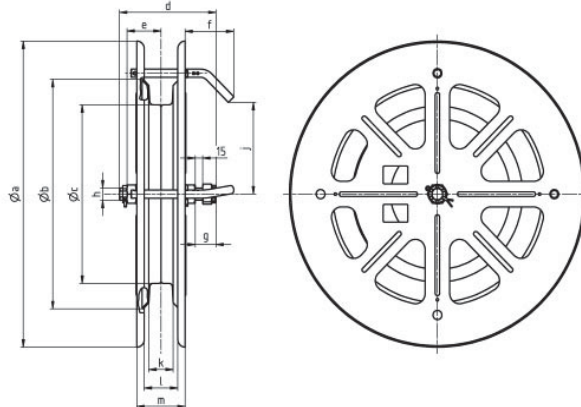

Type Serie LRN

| Type Series | Drawing No. | Drawing No. Marine Design | Weight (kg) | Ø a | Ø b | Ø c | d | e | f |
|-------------|--------------|---------------------------|-------------|-----|-----|-----|-----|----|----|
| LRN 350 | 13-30-00-001 | 13-30-00-000 | 16 | 253 | 450 | 350 | 183 | 70 | 97 |
| LRN 500 | 13-32-01-001 | 13-32-01-000 | 24 | 360 | 650 | 530 | 240 | 82 | 88 |

| Type Series | Drawing No. | Drawing No. Marine Design | Weight (kg) | g | h | j | k | l | m |
|-------------|--------------|---------------------------|-------------|----|------|-----|----|----|-----|
| LRN 350 | 13-30-00-001 | 13-30-00-000 | 16 | 45 | M 24 | 180 | 45 | -- | 105 |
| LRN 500 | 13-32-01-001 | 13-32-01-000 | 24 | 59 | M 30 | 280 | 50 | -- | 116 |

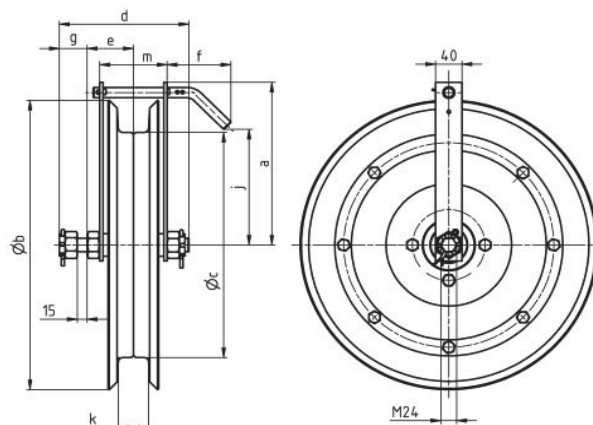



Accessories

Cable Grip, Type Series LZ

Cable grip 800 mm long and galvanised, with 2 thimbles and stainless steel clips. Cable grip is matched with the cable diameter. By the supporting of a cable grip, strain relief occurs in the cable at the feed-in point. Through the grip, surface clamping occurs on the cable and no pointed loading. The cable grip are dimensioned with 3-fold safety factor of the max. tensile force.

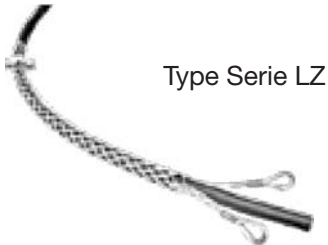

Type Serie LZ

| Type Series | Drawing No. | max. Cable Ø |
|-------------|-------------|--------------|
| LZ 1 | SK-5034-00 | 10 - 15 mm |
| LZ 2 | SK-5034-00 | 15 - 20 mm |
| LZ 3 | SK-5034-00 | 20 - 25 mm |
| LZ 4 | SK-5034-00 | 25 - 30 mm |
| LZ 5 | SK-5034-00 | 30 - 40 mm |

Cable Deposit Roller, Type Series KL

By the supporting of cable deposit roller, permanent contact of the cable with the ground is minimised. Through this, also dirt or damage to the cable is prevented.

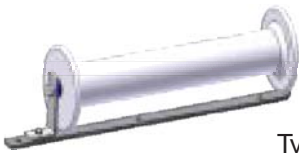

Type Serie KL

| Type Series | Drawing No. | Width |
|-------------|--------------|--------|
| KL 1 | 13-51-00-000 | 200 mm |
| KL 2 | 13-51-01-000 | 300 mm |
| KL 3 | 13-51-02-000 | 400 mm |
| KL 4 | N-030-00A | 800 mm |

Rotary Valve

Rotary valve for air and water at max. 10 bar working pressure of the medium = standard. Nominal width (passage) of the rotary valve is how it is specified in the type series. (Hollow axle of the cable reeling drum is equal or greater than the rotary valve). A torque holder is fitted. If desired, for extra charge, it is provided with additional hood over the rotary valve. Other media such as hydraulic oil, gas, vacuum, special liquids, acids, leaches and similar available on request.



Model Example

| Type Series | max. Pressure | Pressure Medium |
|-------------|---------------|-----------------|
| 1/8" | 10 bar | air |
| 1/8" | 10 bar | water |
| 1/4" | 10 bar | air |
| 1/4" | 10 bar | water |
| 3/8 " | 10 bar | air |
| 3/8" | 10 bar | water |
| 1/2" | 10 bar | air |
| 1/2" | 10 bar | water |
| 3/4" | 10 bar | air |
| 3/4" | 10 bar | water |
| 1" | 10 bar | air |
| 1" | 10 bar | water |
| 1 1/4" | 10 bar | air |
| 1 1/4" | 10 bar | water |
| 1 1/2" | 10 bar | air |
| 1 1/2" | 10 bar | water |



Accessories

Cam Limit Switch

Cam limit switch with switching cams 5 A, 250 V, cam width 40°. Opening under force, for monitoring the position, "Drum full or drum empty".

- I. Cam limit switch with modul housing (IP65) outside the slip ring space, with additional stainless steel (NIROSTA) chain and sprocket wheel.
- II. Cam limit switch without housing (IP20) in the slip ring space.

An additional cam limit switch is possible for all drum types. The pole number must be determined by the customer. In series production we use 2 - 4 - 6 - 8 or 10 contacts. Other contact variants are possible upon request, e.g. with a potentiometer or proximity switch. These limit switches do not serve as safety switches. For further information, we are always at your disposal.

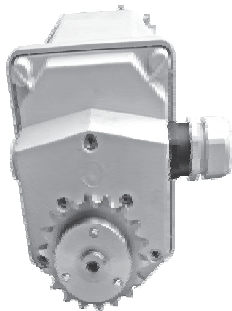

Type I: IP66 with modul housing

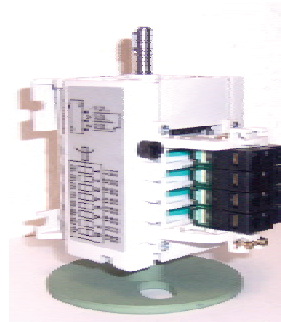

Type II: IP20 without modul housing

Spiral Spring

Spiral leaf springs for spring-loaded cable reeling drums of the specified type series are spirally coiled, rounded and made of compacted special spring steel. These spiral leaf springs are subject to natural wear due to continuous flexural fatigue. The best suitable material is used for manufacture. After the anticipated spring play approx. 120.000, fatigue features become apparent and can lead to fracture of the spiral leaf springs. Under flexural play, also called spring play, one does not understand the entire spring windings, but rather a play occurs even then, when the spring is moved in only a part of the winding. The spiral leaf spring is hung with an eyelet in the cable drum. Axial hanging takes place via a groove on the axle. Using a special hook design of the spring, it is possible to change the coiling direction of the cable reeling drum.

Drum springs are excluded from guarantee.

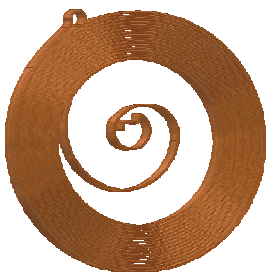

Model Example

| Type Series | Outer Ø (mm) | Inner Ø (mm) |
|-------------|--------------|--------------|
| 508 | 140 | 36 |
| 531 | 170 | 36 |
| 551 | 205 | 36 |
| 524 | 315 | 50 |
| 525 | 315 | 50 |
| 552 | 280 | 45 |
| 553 | 400 | 60 |
| 572 | 280 | 45 |
| 583 | 400 | 60 |
| 585 | 505 | 85 |
| 586 | 505 | 85 |



Accessories

Slip Ring Body, blocked YB 3 + Earth

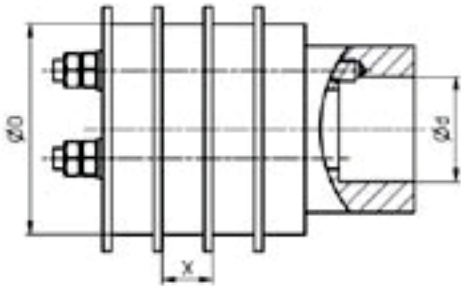

| Current Rating A | 26 | 32 | 36 | 40 | 42 |
|---------------------------|----|----|----|----|----|
| Outer $\varnothing D$ | 50 | 80 | 80 | 50 | 80 |
| Bore Hole $\varnothing D$ | 30 | 55 | 55 | 25 | 55 |
| Distance X | 12 | 8 | 12 | 12 | 12 |

| Current Rating A | 60 | 125 | 150 | 220 | 265 | 500 |
|---------------------------|----|-----|-----|-----|-----|-----|
| Outer $\varnothing D$ | 80 | 98 | 130 | 130 | 200 | 200 |
| Bore Hole $\varnothing D$ | 55 | 55 | 80 | 80 | 100 | 100 |
| Distance X | 14 | 25 | 17 | 22 | 58 | 58 |

Slip Ring Body, air gap YL 3 + Earth

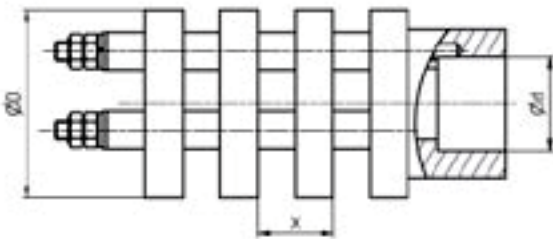

| Current Rating A | 26 | 32 | 36 | 40 | 42 |
|---------------------------|----|----|----|----|----|
| Outer $\varnothing D$ | 50 | 80 | 80 | 50 | 80 |
| Bore Hole $\varnothing D$ | 30 | 55 | 55 | 25 | 55 |
| Distance X | 12 | 8 | 12 | 12 | 12 |

| Current Rating A | 60 | 125 | 150 | 220 | 265 | 500 |
|---------------------------|----|-----|-----|-----|-----|-----|
| Outer $\varnothing D$ | 80 | 98 | 130 | 130 | 200 | 200 |
| Bore Hole $\varnothing D$ | 55 | 55 | 80 | 80 | 100 | 100 |
| Distance X | 14 | 25 | 17 | 22 | 58 | 58 |

Slip Ring

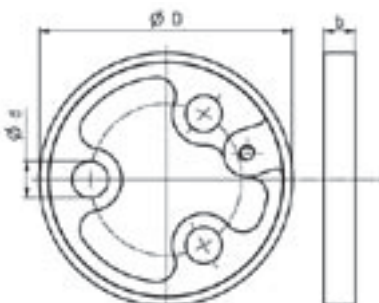

*** Slip rings – earth are not exchangeable with phase slip rings. ***

| Current Rating A | 26 | 32 | 36 | 40 | 42 | 60 |
|--------------------------|-----|------|------|-----|------|------|
| Outer $\varnothing D$ | 50 | 80 | 80 | 50 | 80 | 80 |
| Width b | 10 | 6 | 10 | 10 | 10 | 12 |
| Phasen - $\varnothing d$ | 8.5 | 11.5 | 11.5 | 8.5 | 11.5 | 11.5 |
| Earth - $\varnothing d$ | 5.5 | 11.5 | 11.5 | 5.5 | 6.5 | 6.5 |

| Current Rating A | 125 | 150 | 220 | 265 | 500 | 1000 |
|--------------------------|------|------|------|------|------|------|
| Outer $\varnothing D$ | 98 | 130 | 130 | 200 | 200 | 340 |
| Width b | 15 | 15 | 20 | 28 | 28 | 30 |
| Phasen - $\varnothing d$ | 12.5 | 12.5 | 12.5 | 16.5 | 16.5 | 16.6 |
| Earth - $\varnothing d$ | 8.5 | 8.5 | 8.5 | 12.5 | 12.5 | 12.5 |

Brush Holder Unit complete 3 + Earth

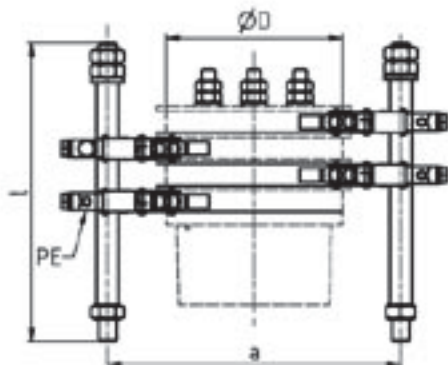

| Current Rating A | 26 | 32 | 36 | 40 | 42 | 60 |
|------------------|-----|-----|-----|-----|-----|-----|
| $\varnothing D$ | 50 | 80 | 80 | 50 | 80 | 80 |
| a | 104 | 133 | 133 | 104 | 133 | 150 |

| Current Rating A | 125 | 150 | 220 | 265 | 500 | 1000 |
|------------------|-----|-----|-----|-----|-----|------|
| $\varnothing D$ | 98 | 130 | 130 | 200 | 200 | 340 |
| a | 146 | 224 | 224 | 300 | 300 | 460 |

Dimension l is variable based on design on the spring cable reeling drum.



Accessories

Brush Holder - Earth

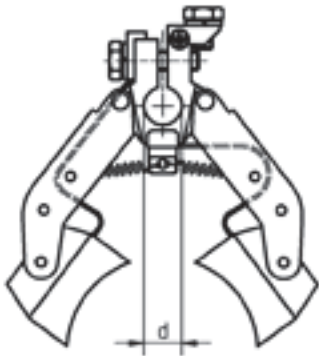

| Current Rating A | 26 | 32 | 36 | 40 | 42 | 60 |
|------------------|----|----|----|----|----|----|
| Dimension Ø d | 10 | 10 | 10 | 10 | 10 | 13 |

| Current Rating A | 125 | 150 | 220 | 265 | 500 | 1000 |
|------------------|-----|-----|-----|-----|-----|------|
| Dimension Ø d | 16 | 16 | 17 | 17 | 17 | 17 |

*** Brush holders - earth are not exchangeable with phase brush holders. ***

Brush Holder - Phase

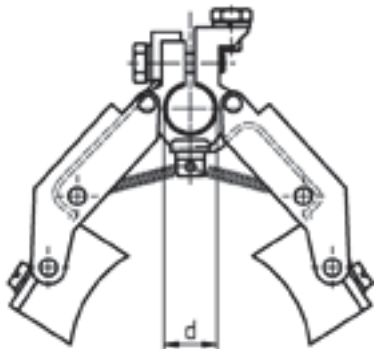

| Current Rating A | 26 | 32 | 36 | 40 | 42 | 60 |
|------------------|----|----|----|----|----|----|
| Dimension Ø d | 8 | 8 | 8 | 8 | 8 | 12 |

| Current Rating A | 125 | 150 | 220 | 265 | 500 | 1000 |
|------------------|-----|-----|-----|-----|-----|------|
| Dimension Ø d | 15 | 16 | 16 | 16 | 16 | 16 |



Questionnaire

1. Track length of consumer

L = _____ m

2. Which cable length should be wound on the drum?
I = _____ m

(for cable fixed point in the middle of track, cable length is half track length)

3. Coiling type

- spiral
 cylindrical
 3.2.3 coiling

4. For use of intended cable type

_____ mm²
cable Ø _____ mm²
cable weight _____ kg/m

5. Power to be transmitted and current rating

_____ kW
_____ A

6. What % of installed power comes into application?

7. How many insulated slip rings are needed?

(our drums are always provided with non-insulated earth ring)

8. For which device is the drum used?

(e.g. construction crane, crane bridge, ravelling platform, etc.)

9. Should the drum be fixed or attached to a movable equipment ?

10. Cable payout

- horizontal (plane)
vertical (perpendicular)
suspended version
(see arrangement examples)

11. Mounting height

_____ m

(from drum middle to the cable deposit)

12. Drum drive by means of springs
Counterweight
electric motor

13. Operating voltage and type of current for drum motor

_____ V

14. How many times per hour does the equipment move ?

_____ /h

15. Working time in hours per day ?

_____ /h

16. Travelling and stroke speed

_____ m/min

17. Starting time

_____ s

18. Cable deposit

- between the tracks
outside the tracks

19. Payout direction

- right
left
(always viewed from slip ring)

20. Arrangement of drums

(for figures, see page 4)

- | | | | |
|---|--------------------------|---|--------------------------|
| A | <input type="checkbox"/> | E | <input type="checkbox"/> |
| B | <input type="checkbox"/> | F | <input type="checkbox"/> |
| C | <input type="checkbox"/> | G | <input type="checkbox"/> |
| D | <input type="checkbox"/> | H | <input type="checkbox"/> |

21. Extraordinary ambient conditions:

Mounting height for more than 1000 m above

sea level _____
or underground _____
humidity _____ %

strong vibrations yes

explanation _____
no

Noise level in db according to DIN 45633

sheet.1 _____

ambient temperature in C°

from _____
to _____

Ambient air

- sand dust
coal dust
salty water

Other media or application areas

22. Painting

priming and cover coat according to RAL 7031 (normal version)

- Hot-dip galvanised
sand blasting
other surface treatments

For larger drums please send us a drawing or sketch of the installation or attachment conditions.



Technical Explanatory Notes

Cable Data, Current Rating, Conversion Factor, Calculating Formula

Cable Data

| 4 core | | |
|-----------------|------|-------------|
| mm ² | Ø mm | Weight kg/m |
| 1.5 | 11.1 | 0.155 |
| 2.5 | 12.1 | 0.208 |
| 4.0 | 13.4 | 0.281 |
| 6.0 | 14.8 | 0.372 |
| 10.0 | 18.8 | 0.611 |
| 16.0 | 23.4 | 0.924 |
| 25.0 | 27.1 | 1.270 |
| 35.0 | 29.7 | 1.720 |
| 50.0 | 35.1 | 2.630 |
| 70.0 | 41.8 | 3.326 |
| 95.0 | 49.2 | 4.695 |
| 120.0 | 54.3 | 5.565 |
| 150.0 | 58.9 | 6.933 |

| 5 core | | |
|-----------------|------|-------------|
| mm ² | Ø mm | Weight kg/m |
| 1.5 | 11.8 | 0.178 |
| 2.5 | 12.8 | 0.241 |
| 4.0 | 14.5 | 0.318 |
| 6.0 | 16.1 | 0.426 |
| 10.0 | 20.5 | 0.704 |
| 16.0 | 23.0 | 1.067 |
| - | - | - |
| - | - | - |
| - | - | - |
| - | - | - |
| - | - | - |
| - | - | - |
| - | - | - |
| - | - | - |
| - | - | - |

| 7 core | | |
|-----------------|------|-------------|
| mm ² | Ø mm | Weight kg/m |
| 1.5 | 13.3 | 0.231 |
| 2.5 | 14.0 | 0.308 |

| 12 core | | |
|-----------------|------|-------------|
| mm ² | Ø mm | Weight kg/m |
| 1.5 | 16.9 | 0.359 |
| 2.5 | 20.2 | 0.480 |

| Normal cross section | | |
|----------------------|------|-------------|
| wire mm ² | Ø mm | Weight kg/m |
| 18 x 1.5 | 17.9 | 0.474 |
| 18 x 2.5 | 20.5 | 0.679 |
| 24 x 1.5 | 22.6 | 0.590 |
| 24 x 2.5 | 25.5 | 0.820 |
| 30 x 1.5 | 24.2 | 0.710 |
| 30 x 2.5 | 28.7 | 0.970 |
| 42 x 1.5 | 28.5 | 0.980 |

Calculating Formula

| | |
|---|--|
| Ohm's Law | $U = I \times R$ |
| Current heat | $W = I^2 \times R \times t$ |
| Resistance of a conductor (supply and return) | $R = \frac{2 \times l}{\chi \times A}$ |
| Direct current power | $P = U \times I$ |
| Alternating current – real power | $P = U \times I \times \cos \varphi$ |
| Three-phase current - real power | $P = \sqrt{3} \times U \times I \times \cos \varphi$ |
| Efficiency | $\eta = \frac{P_{ab}}{P_{zu}}$ |

| | |
|-----------------------|---|
| U | Operating voltage in V (Volt) in two-wire plants between the two conductors, in direct current three-wire plants between two main conductors. |
| u | Voltage drop in V from the beginning to the end of the conductor |
| I | Current in a conductor in A (Amper) |
| R | Resistance in Ω (Ohm) |
| W | Work in Ws (Watt second) |
| P | Power in W (Watt) |
| P_{ab} | Dissipated power in W (Watt) |
| P_{zu} | Supplied power in W (Watt) |

| | |
|--------------|---|
| η | (Eta) Efficiency |
| χ | (Kappa) Conductivity in $\frac{S \times m}{mm^2}$ e.g. for copper approx. 56 |
| cos φ | (Phi) Power factor |
| A | Cross-section of the conductor in mm ² |
| l | One-way length of the conductor section to be considered in m |
| t | Time in s (second) |
| V max | Traveller speed (horizontal) Stroke speed (vertical) in m/min |

Current Rating (without consideration of the voltage drop)

| Nominal cross section mm ² | Rating in ...% DC | | | |
|---------------------------------------|-------------------|-----|-----|-----|
| | 100% | 60% | 40% | 20% |
| 1.5 | 23 | 23 | 23 | 23 |
| 2.5 | 30 | 30 | 30 | 30 |
| 4.0 | 41 | 41 | 42 | 45 |
| 6.0 | 53 | 54 | 55 | 62 |
| 10.0 | 74 | 76 | 80 | 97 |
| 16.0 | 99 | 106 | 115 | 143 |
| 25.0 | 131 | 144 | 161 | 208 |
| 35.0 | 162 | 183 | 208 | 274 |
| 50.0 | 202 | 234 | 270 | 361 |
| 70.0 | 250 | 294 | 409 | 467 |
| 95.0 | 301 | 361 | 427 | 581 |
| 120.0 | 352 | 425 | 506 | 693 |
| 150.0 | 404 | 493 | 589 | 811 |
| 185.0 | 461 | 567 | 81 | 940 |

The specified values apply to single-layer coiling. The values for 100% rating are found in table 2 from DIN 57100, Part 523/VDE 0100 and EN60204-0298. They specify the rating of insulated cables according to Group 2 for ambient temperatures of 30°C as well as a permissible conductor temperature of 60°C.

Conversion Factor

| | | | | | | | |
|---|--------|----------------|--------|------|------|-----|------|
| For the dependence of current rating on the number of layers on the drum at +30°C | | | | | | | |
| Number of layer on the drum | 1 | 2 | 3 | 4 | 5 | | |
| Conversion factor | 0.8 | 0.61 | 0.49 | 0.42 | 0.34 | | |
| For the dependence of rating on ambient temperature Factor | | | | | | | |
| °C | Factor | °C | Factor | | | | |
| above 25 to 30 | 1 | above 40 to 45 | 0.71 | | | | |
| above 30 to 35 | 0.91 | above 45 to 50 | 0.58 | | | | |
| above 35 to 40 | 0.82 | above 50 to 55 | 0.41 | | | | |
| for four-wire conductors | | | | | | | |
| Numbers of loaded wires | 5 | 7 | 10 | 14 | 19 | 24 | 40 |
| Conversion factor | 0.75 | 0.65 | 0.55 | 0.5 | 0.45 | 0.4 | 0.35 |

The conversion factors for deviating ambient temperatures are based on table 3 from DIN 57100/VDE0100, Part 523 and EN 60204-0298. The converted values for the intermittent operation are based on experience. Please observe the reduction of current rating of the conductor in the case of multi-layer coiling.

Voltage drop in Volt

| for | for direct current single-phase alternating current (free of induction $\cos \varphi = 1$) | for three-phase current |
|---------------|---|--|
| given current | $u = \frac{2 \times l \times I}{\chi \times A} (V)$ | $u = \frac{\sqrt{3} \times l \times I \times \cos \varphi}{\chi \times A} (V)$ |
| given power | $u = \frac{2 \times l \times P}{\chi \times A} (V)$ | $u = \frac{l \times P}{\chi \times A} (V)$ |

Cross Section of Cores in mm²

| for | for direct current single-phase alternating current (free of induction $\cos \varphi = 1$) | for three-phase current |
|---------------|---|---|
| given current | $A = \frac{2 \times l \times I}{\chi \times u} (mm^2)$ | $A = \frac{\sqrt{3} \times l \times I \times \cos \varphi}{\chi \times u} (mm^2)$ |
| given power | $A = \frac{2 \times l \times P}{\chi \times u \times U} (mm^2)$ | $A = \frac{l \times P}{\chi \times u \times U} (mm^2)$ |



Technical Explanations

Spring Cable reeling Drum

Notes for Cable reeling Drums

Cable reeling drums are suitable for horizontal application with payout towards 1 or 2 sides, as well as for vertical application downwards and upwards. In this regard, we request you to pay attention to our Questionnaire (page 47) as well as to the arrangement examples (page 4). The cable reeling drums that we manufacture conform to appropriate regulations.

Application Purpose and Selection of Cable reeling Drums

Our manufacture comprises cable reeling drums with the following drive types:

1. Drive via spiral springs, type series LT, LTSCH, LTA, LTB, LTS (slippingless), KTG etc.
2. Drive via counterweight, type series KTG.

Which of these drum drives is suitable for your application purpose depends on different factors. Since all types of drive starting from the well-known spring-loaded drive, via counterweight drive, are at our disposal. We are in a position to select the best drive for your application purpose.

We have attached a Questionnaire (page 47) to this catalogue; if it is properly filled out, we can consider all these factors when preparing an offer, which are necessary for perfect operation of a drum or of a slip ring body. On page 4, there are arrangement examples about how to mount the drum on the equipment. It is recommendable to attach accurate details and possibly a drawing so that we can provide you with correspondingly optimum, installation proposals.

Drum Arrangement

The cable reeling drum has to be located such that the cable at any time, even after running over the middle point, can be freely coiled and uncoiled without hindrance. The cable deposit should, according to the table, occur from maximum 0.5 to 2.5 m underneath the drum axis, outside or inside the tracks. Greater installation heights are possible, but must be drawn to our attention.

Cable Selection or Cable Fixed Point

All cable reeling drums can be paid out towards 1 or 2 sides, based on the feed-in. If fed-in on one side, then the cable length equals to the entire track length. If fed-in, in the middle of the track, then the cable length is equal to only half of the track length. In both cases, for strain relief, 2 safety windings must remain on the drum.

The required cable lengths are calculated as follows:

$L_{\text{required}} = \text{coiled cable length } l + 2 \text{ safety windings for strain relief} + \text{distance from fixed point to terminal box} + \text{from the drum to the slip rings} + \text{the mounting height } h.$

The payout length specified in the lists l (m) may not be exceeded, since this can lead to damage to the spiral leaf spring.

Choosing the Cable

When purchasing the drum-reeled cable, the supplier must be informed that:

- a) The cable must be suitable for forced guidance with constantly intermittent, uniform movements.
- b) Only non-spinning cables with the VDE or EN compliant bending diameters and tensile loads may be used.

The data we have quoted such as diameters, weight, cross-section as well as drum core diameter, bending radius at deflectors and curves conform to VDE or EN regulations or lie above them for safety reasons. For all values, regulations according to VDE0100 or VDE0165 were used. Due to the frequent high level of wear at the place of use, it has been apparent that special cables manufactured by several companies, even though expensive, exhibit long service life and are best suitable for drum-reeling. Experiments and the data determined by us were carried out with a drum-reeled cable. When selecting the cable cross-section, attention should be paid also to static permanent tensile load, based on the overall copper cross-section of the conductor. For concentric cables, the tensile stress reduces. The tensile forces calculated in our catalogue are based on -15°C to $+40^{\circ}\text{C}$. For low temperatures, a higher tensile force is required due to the bending stiffness of the cable.

Winding the Cable

The reeling cable has to be laid on the drum body fully and free from twist.

Please observe our notes in the treatment regulations.

Attention!

Only lay as much cable on the drum, as is specified on the type plate. Two additional windings for strain relief must remain on the drum after paying out the entire cable. These windings have been included in the capacity of the drum body. Appropriate notes are found in our Operating and Maintenance Regulations, which are attached to every cable reeling drum.



Technical Explanations

Spring Cable reeling Drum

Control Cable

All our cables can be equipped with multi-pole slip ring bodies for four pole lines. The number of wires and the cross-section of cables determine the design of the slip ring body.

Operating Voltage

As standard, the drums and slip-rings are rated for up to 500 V three-phase current (3~) or 600V direct current (=). For higher operating voltage, we request for enquiry.

Current Rating

As standard, the drums are designed for current ratings for a duty cycle of S1 (100% duty cycle).

Protective Earth

All our slip ring bodies and drums are provided with non-insulated protective earth. Number of poles is the number of insulated poles, e.g. 3 pole + earth or 11 poles + earth. The protective earth is identifiable and cannot be mistaken for phase.

Drum Body

The drum bodies can be provided both for cylindrical as well as for spiral coiling. To ensure perfect ventilation of cable, large drum bodies are provided with perforated sheet metal jacket and the board sides are in corresponding spoke design.

Cam Limit Switch

Additional attachment of a limit switch is possible for all types. This switch serves for limit switching via the control line of the under carriage. (Not to be used as safety switch for track end).

Limit switches can be operated with alternating current 15 - 250 VAC, or direct current 15 - 30 VDC.

Protection Class

Our standard cable reeling drums can be erected in open air (IP55).

IP55 means: Full protection exists against touching parts under voltage or inner moving parts.

Protection exists against dangerous dust deposits. Entry of dust as such is not fully prevented, but the dust may not enter in such great amounts that operation is impaired.

Other protections systems are available upon request.

Colour Coating

Cable reeling drums are galvanised designed. Other parts are provided with priming or coating in 2 components epoxy resin according to RAL 7031 – blue grey.

Upon request the following surface treatments can be performed:

Other colours, sand blasting and rust primer, hot-dip galvanizing, plastic coating, special coating for maritime environment, etc.

Maintenance

Due to simple design the drums require only minor maintenance. Bearings are provided with lubricant. For roller bearings with higher ambient temperature, our operating and maintenance regulations must be observed. The carbon brushes fitted in the slip ring bodies are subject to natural wear. These must be cleaned accordingly and after approx. 2 /3 of wear replaced.

Ambient Influences

The environment often brings difficult operating conditions and must be accounted for when placing an order for the drum.

Observe the following items:

Extremely high or low outside temperatures, strong temperature fluctuations, erection in great heights, high humidity, strong vibrations, contaminated air, application at sea or in salty air, underground application just to mention several cases of use.

Liability for Faults

If any alterations or repairs to the cable reeling drum are done by anyone else within the time of warranty, we do not take any further liability for faults.

Note

Hartmann & König is developed, constructed and produced according to the

- Low Voltage Directive 2006/95/EG
- EMC Directive 2004/108/EG
- Generally valid manufacturing guidelines according to ISO 9001:2000



General Conditions

of Hartmann & König Stromzuführungs AG (last update: 2005-12)

I. GENERAL

1. The scope of deliveries and/or services (hereinafter referred to as „Supplies“) shall be determined by the written declarations of both Parties. General terms and conditions of the Purchaser shall apply only if and when expressly accepted by the supplier or the provider of services (hereinafter referred to as „Supplier“) in writing.
2. The Supplier herewith reserves any industrial property rights and/or copyrights pertaining to its cost estimates, drawings and other documents (hereinafter referred to as „Documents“). The Documents shall not be made accessible to third parties without the Supplier's prior consent and shall, upon request, be returned without undue delay to the Supplier if the contract is not awarded to the Supplier. Sentences 1 and 2 shall apply mutatis mutandis to documents of the Purchaser; these may, however, be made accessible to third parties to whom the Supplier may rightfully transfer Supplies.
3. The Purchaser shall have the non-exclusive right to use standard software, provided that it remains unchanged, is used within the agreed performance parameters, and on the agreed equipment. The Purchaser may make one back-up copy without express agreement.
4. Partial Supplies shall be allowed, unless they are unreasonable to accept for the Purchaser.

II. PRICES AND TERMS OF PAYMENT

1. Prices shall be ex works and exclude packaging, value added tax shall be added at the then applicable rate.
2. If the Supplier is also responsible for assembly or erection and unless otherwise agreed, the Purchaser shall pay the agreed remuneration and any incidental costs required, e. g. travel costs, costs for the transport of tools and equipment, and personal luggage as well as allowances.
3. Payments shall be made free Supplier's paying office.
4. The Purchaser may set off only those claims that are undisputed or against which no legal recourse is possible.
5. On delay of payment we charge interest payable on arrears.

III. RETENTION OF TITLE

1. Items pertaining to the Supplies („Retained Goods“) shall remain the property of the Supplier until each and every claim the Supplier has against the Purchaser on account of the business connection has been fulfilled. If the combined value of the security interests of the Supplier exceeds the value of all secured claims by more than 20 %, the Supplier shall release a corresponding part of the security interest if so requested by the Purchaser.
2. For the duration of the retention of title, the Purchaser may not pledge the Retained Goods or use them as security, and resale shall be possible only for resellers in the ordinary course of their business and only on condition that the reseller receives payment from its customer or makes the transfer of property to the customer dependent upon the customer fulfilling its obligation to effect payment.
3. The Purchaser shall inform the Supplier forthwith of any seizure or other act of intervention by third parties.
4. Where the Purchaser fails to fulfil its duties, including failure to make payments due, the Supplier shall be entitled to cancel the contract and take back the Retained Goods in the case of continued failure following expiry of a reasonable time set by the Supplier; the statutory provisions that a time limit is not needed remain unaffected. The Purchaser shall be obliged to surrender the Retained Goods.

IV. TIME FOR SUPPLIES; DELAY

1. Times set for Supplies can only be observed if all Documents to be supplied by the Purchaser, necessary permits and releases, especially concerning plans, are received in time and if agreed terms of payment and other obligations of the Purchaser are fulfilled. Unless these conditions are fulfilled in time, times set shall be extended appropriately, this shall not apply where the Supplier is responsible for the delay.
2. If non-observance of the times set is due to force majeure such as mobilization, war, rebellion or similar events, e. g. strike or lockout, such time shall be extended accordingly.
3. If the Supplier is responsible for the Delay (hereinafter referred to as „Delay“) and the Purchaser demonstrably suffered a loss therefrom, the Purchaser may claim a compensation as liquidated damages of 0.5 % for every completed month of Delay, but in no case more than a total of 3 % of the price of that part of the Supplies which because of the delay could not be put to the intended use.

4. Purchaser's claims for damages due to delayed Supplies as well as claims for damages in lieu of performance exceeding the limits specified in No. 3 above shall be excluded in all cases of delayed Supplies even upon expiry of a time set to the Supplier to effect the Supplies. This shall not apply in cases of mandatory liability based on intent, gross negligence, or due to injury of life, body or health. Cancellation of the contract by the Purchaser based on statute shall be limited to cases where the Supplier is responsible for the delay. The above provisions do not imply a change in the burden of proof to the detriment of the Purchaser.
5. At the Supplier's request the Purchaser shall declare within a reasonable period of time whether the Purchaser cancels the contract due to the delayed Supplies or insists on the Supplies to be carried out.
6. If dispatch or shipment is delayed at the Purchaser's request by more than one month after notice of the readiness for dispatch was given, the Purchaser may be charged, for every month commenced, storage costs of 0.5 % of the price of the items of the Supplies, but in no case more than a total of 5 %. The parties to the contract may prove that higher or, as the case may be, lower storage costs have been incurred.

V. TRANSFER OF RISK

1. Even where delivery has been agreed freight free, the risk shall pass to the Purchaser as follows:
 - a) if the Supplies do not include assembly or erection, at the time when the Supplies are shipped or picked up by the carrier. Upon request of the Purchaser, the Supplier shall insure the Supplies against the usual risks of transport at the expense of the Purchaser;
 - b) if the Supplies include assembly or erection, at the day of taking over in the own works or, if so agreed, after a fault-free trial run.
2. The risk shall pass to the Purchaser if dispatch, shipping, the start or performance of assembly or erection, the taking over in the own works or the trial run is delayed for reasons for which the Purchaser is responsible or if the Purchaser has otherwise failed to accept the Supplies.

VI. ASSEMBLY AND ERECTION

Unless otherwise agreed in writing, assembly/erection shall be subject to the following provisions:

1. The Purchaser shall provide at its own expense and in good time:
 - a) all earth and construction work and other ancillary work outside the scope of the Supplier, including the necessary skilled and unskilled labour, construction materials and tools,
 - b) the equipment and materials necessary for assembly and commissioning such as scaffolds, lifting equipment and other devices as well as fuels and lubricants,
 - c) energy and water at the point of use including connections, heating and lighting,
 - d) suitable dry and lockable rooms of sufficient size adjacent to the site for the storage of machine parts, apparatus, materials, tools, etc. and adequate working and recreation rooms for the erection personnel, including sanitary facilities as are appropriate in the specific circumstances. Furthermore, the Purchaser shall take all measures it would take for the protection of its own possessions to protect the possessions of the Supplier and of the erection personnel at the site,
 - e) protective clothing and protective devices needed due to particular conditions prevailing on the specific site.
2. Before the erection work starts, the Purchaser shall make available of its own accord any information required concerning the location of concealed electric power, gas and water lines or of similar installations as well as the necessary structural data.
3. Prior to assembly or erection, the materials and equipment necessary for the work to start must be available on the site of assembly/erection and any preparatory work must have advanced to such a degree that assembly/erection can be started as agreed and carried out without interruption. Access roads and the assembly/erection site itself must be level and clear.
4. If assembly, erection or commissioning is delayed due to circumstances for which the Supplier is not responsible, the Purchaser shall bear the reasonable costs incurred for idle times and any additional travelling of the Supplier or the erection personnel.
5. The Purchaser shall attest to the hours worked by the erection personnel towards the Supplier at weekly intervals and the Purchaser shall immediately confirm in writing if assembly, erection or commissioning has been completed.



General Conditions of Hartmann & König Stromzuführungs AG (last update: 2005-12)

6. If, after completion, the Supplier demands acceptance of the Supplies, the Purchaser shall comply therewith within a period of two weeks. In default thereof, acceptance is deemed to have taken place. Acceptance is also deemed to have been effected if the Supplies are put to use, after completion of an agreed test phase, if any.

VII. RECEIVING OF SUPPLIES

The Purchaser shall not refuse to receive Supplies due to minor defects.

VIII. DEFECTS AS TO QUALITY

The Supplier shall be liable for defects as to quality („*Sachmängel*“, hereinafter referred to as „*Defects*“,) as follows:

1. All parts or services where a Defect becomes apparent within the limitation period shall, at the discretion of the Supplier, be repaired, replaced or provided again free of charge irrespective of the hours of operation elapsed, provided that the reason for the Defect had already existed at the time when the risk passed.
2. Claims based on Defects are subject to a limitation period of 12 months. This provision shall not apply where longer periods are prescribed by law according to Sec. 438 para. 1 No. 2 (buildings and things used for a building), Sec. 479 para. 1 (right of recourse), and Sec. 634a para. 1 No. 2 (defects of a building) German Civil Code („*BGB*“), as well as in cases of injury of life, body or health, or where the Supplier intentionally or grossly negligently fails to fulfil its obligation or fraudulently conceals a Defect. The legal provisions regarding suspension of expiration („*Ablaufhemmung*“), suspension („*Hemmung*“) and commencement of limitation periods remain unaffected.
3. The Purchaser shall notify Defects to the Supplier in writing and without undue delay.
4. In the case of notification of a Defect, the Purchaser may withhold payments to a reasonable extent taking into account the Defect occurred. The Purchaser, however, may withhold payments only if the subject-matter of the notification of the Defect occurred is justified beyond doubt. Unjustified notifications of Defect shall entitle the Supplier to have its expenses reimbursed by the Purchaser.
5. The Supplier shall first be given the opportunity to supplement its performance („*Nacherfüllung*“) within a reasonable period of time.
6. If supplementary performance is unsuccessful, the Purchaser shall be entitled to cancel the contract or reduce the remuneration, irrespective of any claims for damages it may have according to Art. XI.
7. There shall be no claims based on Defect in cases of insignificant deviations from the agreed quality, of only minor impairment of usefulness, of natural wear and tear or damage arising after the transfer of risk from faulty or negligent handling, excessive strain, unsuitable equipment, defective workmanship, inappropriate foundation soil or from particular external influences not assumed under the contract, or from non-reproducible software errors. Claims based on defects attributable to improper modifications or repair work carried out by the Purchaser or third parties and the consequences thereof shall be likewise excluded.
8. The Purchaser shall have no claim with respect to expenses incurred in the course of supplementary performance, including costs of travel and transport, labour, and material, to the extent that expenses are increased because the subject-matter of the Supplies was subsequently brought to another location than the Purchaser's branch office, unless doing so complies with the intended use of the Supplies.
9. The Purchaser's right of recourse against the Supplier pursuant to Sec. 478 BGB is limited to cases where the Purchaser has not concluded an agreement with its customers exceeding the scope of the statutory provisions governing claims based on Defects. Moreover, No. 8 above shall apply *mutatis mutandis* to the scope of the right of recourse the Purchaser has against the Supplier pursuant to Sec. 478 para. 2 BGB.
10. Furthermore, the provisions of Art. XI (Other Claims for Damages) shall apply in respect of claims of damages. Any other claims of the Purchaser against the Supplier or its agents or any such claims exceeding the claims provided for in this Art. VIII, based on a Defect, shall be excluded.

IX. INDUSTRIAL PROPERTY RIGHTS AND COPYRIGHT; DEFECTS IN TITLE

1. Unless otherwise agreed, the Supplier shall provide the Supplies free from third parties' industrial property rights and copyrights (hereinafter referred to as „*IPR*“) with respect to the country of the place of destination. If a third party asserts a justified claim against the Purchaser based on an infringement of an IPR with respect to the Supplies made by the Supplier and then used in conformity with the contract, the Supplier shall be liable to the Purchaser within the time period stipulated in Art. VIII No. 2 as follows:
 - a) The Supplier shall choose whether to acquire, at its own expense, the right to use the IPR with respect to the Supplies concerned or whether to modify the Supplies such that they no longer infringe the IPR or replace them. If this would be unreasonable to demand from the Supplier, the Purchaser may cancel the contract or reduce the remuneration pursuant to the applicable statutory provisions.
 - b) The Supplier's liability to pay damages shall be governed by Art. XI.
 - c) The above obligations of the Supplier shall only apply if the Purchaser (i) immediately notifies the Supplier of any such claim asserted by the third party in writing, (ii) does not concede the existence of an infringement and (iii) leaves any protective measures and settlement negotiations to the discretion of the Supplier. If the Purchaser stops using the Supplies in order to reduce the damage or for other good reason, it shall be obliged to point out to the third party that no acknowledgement of the alleged infringement may be inferred from the fact that the use has been discontinued.

2. Claims of the Purchaser shall be excluded if it is itself responsible for the infringement of an IPR.
3. Claims of the Purchaser shall also be excluded if the infringement of the IPR is caused by specifications made by the Purchaser, to a type of use not foreseeable by the Supplier or to the Supplies being modified by the Purchaser or being used together with products not provided by the Supplier.
4. In addition, with respect to claims by the Purchaser pursuant to No. 1 a) above, Art. VIII Nos. 4, 5, and 9 shall apply *mutatis mutandis* in the event of an infringement of an IPR.
5. Where other defects in title occur, Art. VIII shall apply *mutatis mutandis*.
6. Any other claims of the Purchaser against the Supplier or its agents or any such claims exceeding the claims provided for in this Art. IX, based on a defect in title, shall be excluded.

X. IMPOSSIBILITY OF PERFORMANCE; ADAPTATION OF CONTRACT

1. To the extent that Supplies are impossible to be carried out, the Purchaser shall be entitled to claim damages, unless the Supplier is not responsible for the impossibility. The Purchaser's claim for damages shall, however, be limited to an amount of 10 % of the value of the part of the Supplies which, owing to the impossibility, cannot be put to the intended use. This limitation shall not apply in the case of mandatory liability based on intent, gross negligence or injury of life, body or health; this does not imply a change in the burden of proof to the detriment of the Purchaser. The right of the Purchaser to cancel the contract shall remain unaffected.
2. Where unforeseeable events within the meaning of Art. IV No. 2 substantially change the economic importance or the contents of the Supplies or considerably affect the Supplier's business, the contract shall be adapted taking into account the principles of reasonableness and good faith. Where doing so is economically unreasonable, the Supplier shall have the right to cancel the contract. If the Supplier intends to exercise its right to cancel the contract, it shall notify the Purchaser thereof without undue delay after having realised the repercussions of the event; this shall also apply even where an extension of the delivery period had previously been agreed with the Purchaser.

XI. OTHER CLAIMS FOR DAMAGES

1. Any claims for damages and reimbursement of expenses the Purchaser may have (hereinafter referred to as „*Claims for Damages*“), based on whatever legal reason, including infringement of duties arising in connection with the contract or tort, shall be excluded.
2. The above shall not apply in the case of mandatory liability, e. g. under the German Product Liability Act („*Produkthaftungsgesetz*“), in the case of intent, gross negligence, injury of life, body or health, or breach of a condition which goes to the root of the contract („*wesentliche Vertragspflichten*“). However, Claims for Damages arising from a breach of a condition which goes to the root of the contract shall be limited to the foreseeable damage which is intrinsic to the contract, unless caused by intent or gross negligence or based on liability for injury of life, body or health. The above provision does not imply a change in the burden of proof to the detriment of the Purchaser.
3. To the extent that the Purchaser has a valid Claim for Damages according to this Art. XI, it shall be time-barred upon expiration of the limitation period applicable to Defects pursuant to Art. VIII No. 2. In the case of claims for damages under the German Product Liability Act, the statutory provisions governing limitation periods shall apply.

XII. VENUE AND APPLICABLE LAW

1. If the Purchaser is a businessperson, sole venue for all disputes arising directly or indirectly out of the contract shall be the Supplier's place of business. However, the Supplier may also bring an action at the Purchaser's place of business.
2. Legal relations existing in connection with this contract shall be governed by German substantive law, to the exclusion of the United Nations Convention on Contracts for the International Sale of Goods (CISG).
3. Place of Execution is 76676 Graben – Neudorf (Germany).

XIII. SEVERABILITY CLAUSE

The legal invalidity of one or more provisions of this contract shall in no way affect the validity of the remaining provisions. This shall not apply if it would be unreasonable for one of the parties to continue the contract.

Hartmann & König
Stromzuführungs AG

TO WIRE UP · TO FIX · TO CREATE · TO CONSTRICT ·
TO COMBINE · TO **CONCEIVE** · TO EXTEND · TO
ENHANCE · TO CHANGE · TO TAKE RESPONSIBI-
LITY · TO CONFIDE · TO WORK · TO IMPROVE · TO
DRAW · TO CONCEAL · TO TWIST · TO BEND · TO COM-
PARE · TO ENLARGE · TO SHRINK · TO ENCASE · TO
LINK · TO **CONNECT** · TO CONVEY · TO GALVANIZE ·
TO DRILL · TO SAW · TO CHOOSE · TO MOUNT ·
TO FOLLOW · TO PLAN ON · TO PACK · TO LOCK · TO
SEAL · TO SEND · TO CUT · TO WELD · TO DISTRI-
BUTE · TO MAKE · TO **CONDUCT** · TO STORE · TO
CONVERT · TO SCREW · TO ADVISE · TO PULL

